



# ***EVBnet02***

**Evaluation Board for  
MMnet02**

---

## **User's Manual**

REV 1

**PROPOX**®  
Many ideas one solution

# Contents

<b>1 INTRODUCTION .....</b>	<b>3</b>
FEATURES .....	3
<b>2 THE BOARD.....</b>	<b>4</b>
PLACEMENT OF ELEMENTS ON THE BOARD .....	4
ARRANGEMENT ON LEAD-OUTS .....	5
BOARD SUPPLY .....	6
LED DIODES.....	6
PUSH-BUTTONS.....	7
LCD DISPLAY .....	7
POTENTIOMETERS.....	8
BUZZER .....	8
RESET BUTTON .....	9
RS-232 INTERFACE .....	9
1-WIRE INTERFACE.....	10
CONNECTION TO THE ETHERNET NETWORK .....	11
ISP AND JTAG CONNECTORS .....	12
<b>3 TECHNICAL ASSISTANCE .....</b>	<b>13</b>
<b>4 GUARANTEE .....</b>	<b>13</b>
<b>5 BOARD LAYOUT AND DIMENSIONS.....</b>	<b>14</b>
<b>6 SCHEMATICS.....</b>	<b>14</b>

# Introduction

---

The EVBnet02 board was created with the aim of providing a hardware base for a designer of systems relying on the MMnet02 minimodule, allowing to realize and verify quickly one's own ideas. Having this in mind, the board has been designed in such a way that the user has access to all terminals of the module which are led out to connectors. The board houses also such peripherals as: LEDs, push-buttons, potentiometers, a LCD display, a RS232 interface, a 1-Wire connector. All these elements are accessible through pin connectors, permitting their connection with any processor port. The board has also a large prototype area which permits the designer to connect other elements in any configuration. Due to the incision (v-cut) between the prototype area and the rest of the board, the prototype part can be broken off. The board contains also a power supply which relieves the user from the need to provide a regulated supply voltage. Together with the board, we deliver source codes of the Nut/OS together with the TCP/IP stack as well as demonstration software.

The EVBnet02 along with the MMnet02 minimodule can be also used in didactic laboratories of informatics colleges and universities, illustrating aspects of co-operation of electronic circuits with the Ethernet/Internet networks. It can be also used to build circuits realizing thesis projects.

**We wish you nothing but success and a lot of satisfaction in designing and developing new electronic equipment based on the EVBnet02 board and the Mmnet02 minimodule.**

## Features

---

- Socket for the MMnet02 module
- Connector with all terminals of the MMnet02 module
- Connectors of all peripherals accessible on board
- Power supply (supplying power is taken from a standard socket or supplied through the Ethernet cable)
- Power switch
- RJ45 Ethernet socket with transformer
- RS232 port
- 1-Wire connector
- Connector for In System Programming
- Multiplexer separating the ISP connector from the rest of the system
- JTAG connector for in system programming and debugging
- 2x16 LCD display <sup>(1)</sup>
- 8 LED diodes
- 4 push-buttons
- 2 potentiometers
- Buzzer
- Prototype design area

**Notice:** 1. Mounted optionally

## 2 The Board

### Placement of elements on the board

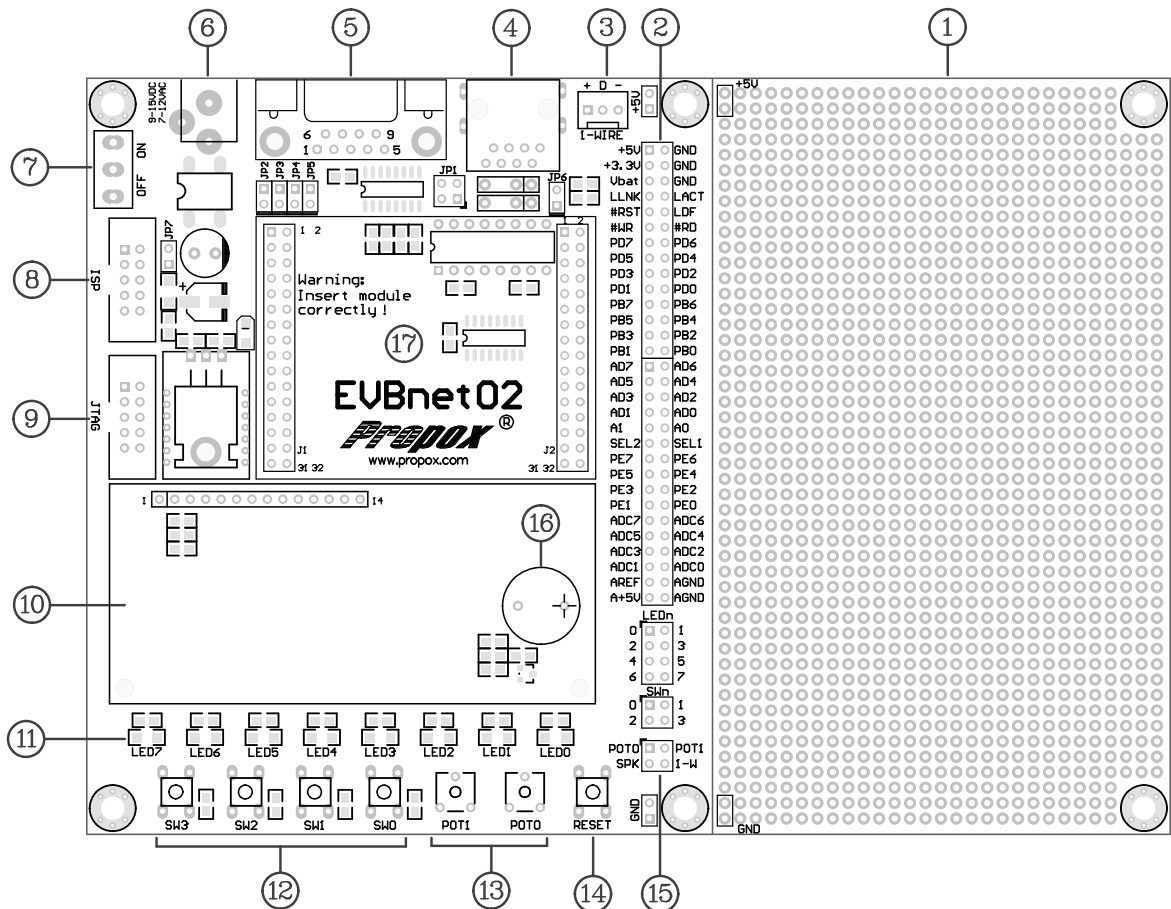

Figure 1 Placement of elements on the EVBnet02 board.

1. Prototype area
2. Connector with led-out MMnet02 module terminals
3. 1-Wire connector
4. RJ45 Ethernet connector
5. RS232 connector
6. Supply connector
7. Power switch
8. Programming connector in the JTAG system
9. Programming/emulation connector in the JTAG system
10. LCD display
11. LED diodes
12. Push-buttons
13. Potentiometers
14. RESET button
15. Peripheral connectors
16. Buzzer
17. MMnet02 module

## Arrangement on lead-outs

Numbering of terminals is in accord with the numeration in the MMnet02 minimodule. The terminals of Ethernet controller TPIN, TUPOT have not been led out to a connector.

Function in MMnet02	Name		Name	Function in MMnet02	
	+5V	1	2	GND	
	+3.3V	3	4	GND	
	Vbat	5	6	GND	
	LEDLINK	11	12	LEDACT	
	#RESET	13	14	LEDDF	
	#WR	15	16	#RD	
	PD7/T2	17	18	PD6/ T1	
	PD5	19	20	PD4/ IC1	
	PD3/#INT3/TxD1	21	22	PD2/#INT2/RxD1	
RTC – SDA	PD1/#INT1/SDA	23	24	#INT0/SCL	RTC – SCL
	PB7/ OC2/PWM2	25	26	OC1B/PWM1B	DataFlash2 - #CS
DataFlash1 – #CS	PB5/ OC1A/PWM1A	27	28	OC0/PWM0	
DataFlash1/2 – MISO	PB3/ MISO	29	30	MOSI	DataFlash1/2 - MOSI
DataFlash1/2 – SCK	PB1/ SCK	31	32	PB0/#SS	
	AD7	1	2	AD6	
	AD5	3	4	AD4	
	AD3	5	6	AD2	
	AD1	7	8	AD0	
	A1	9	10	A0	
	SEL2	11	12	SEL1	
RTL8019AS interrupt	PE7/ INT7	13	14	PE6/ INT6	
RTL8019AS int. (opt.)	PE5/ INT5	15	16	PE4/ INT4	
	PE3/ AC-	17	18	PE2/ AC+	
	PE1/ PDO/TPD	19	20	PE0/ PDI/RxD	
	PF7/ ADC7/TDI	21	22	PF6/ ADC6/TDO	
	PF5/ ADC5/TMS	23	24	PF4/ ADC4/TCK	
	PF3/ADC3	25	26	PF2/ ADC2	
	PF1/ ADC1	27	28	PF0/ ADC0	
	AREF	29	30	AGND	
	A+5V	31	32	AGND	

## Board supply

The EVBnet02 board can be supplied in two ways:

- From an external power supply with an output of 7-12 V AC or 9-15 V DC, having a standard plug with a bolt diameter of 2.1 mm, connected to supply socket J3. In case of a DC supply voltage its polarity is irrelevant.
- Through the J5 Ethernet connector. The terminals of the connector to which the supplying power is applied should conform to the Power over Ethernet 802.3af standard (however, the applied voltage should not be higher than 12V AC !). In order to apply power through the RJ45 connector, the board should be provided with JP1 jumpers.

The regulated + 5 V voltage is led out to the J1 connector (+ 5V) and J14 (GND).

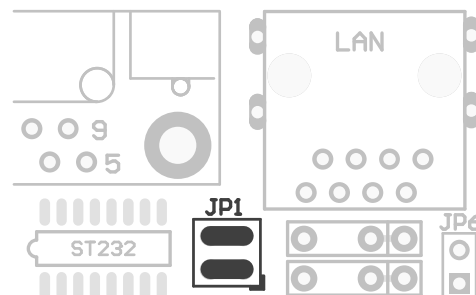

Both supply methods should not be used simultaneously.

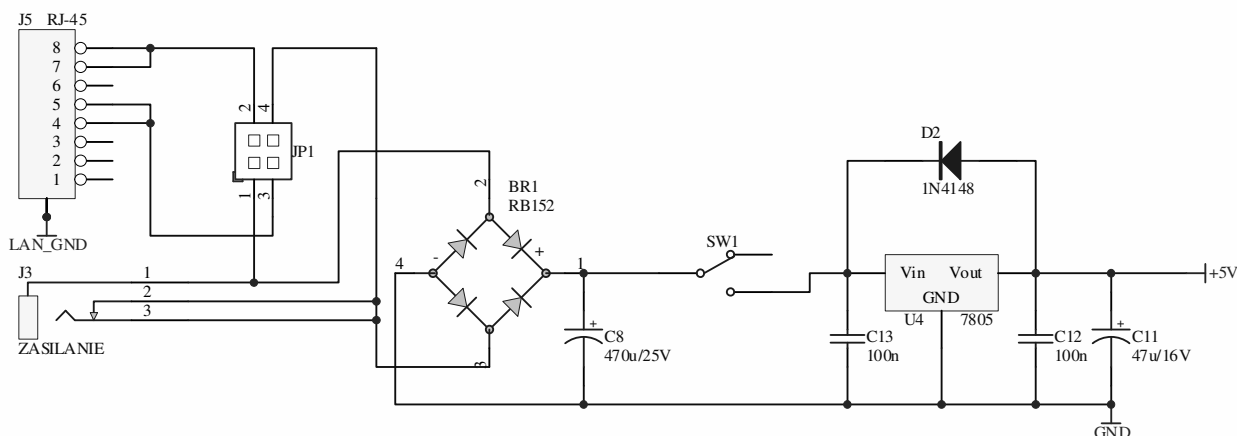

Figure 2 Implementation of the power supply on the EVBnet02 board.

## LED diodes

The EVBnet02 has 8 LED diodes which play the role of the simplest interface between the system and the user. The board is constructed in such a way that it allows any connection between the diodes and microcontroller leads. A diode lights up when a low signal level is applied to appropriate leads. The LED current flowing into the microcontroller pin is about 3 mA.

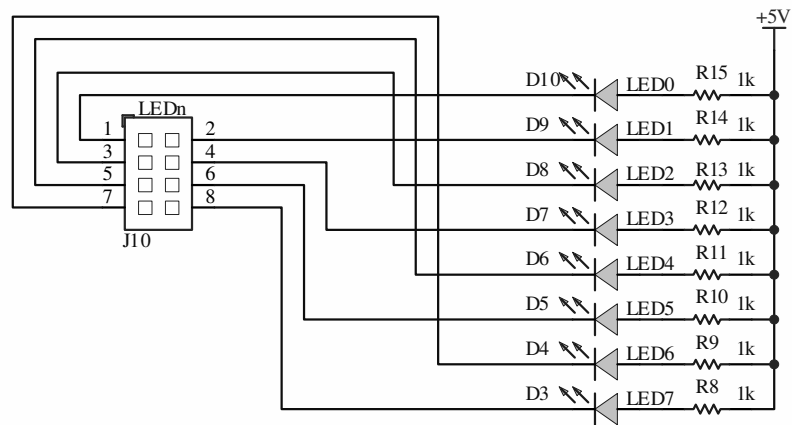

Figure 3 Implementation of LED diodes.

## Push-buttons

The EVBnet02 board is equipped with four microswitches which can be connected to any lead of the microcontroller. Pushing a button causes a low state on any port terminal.

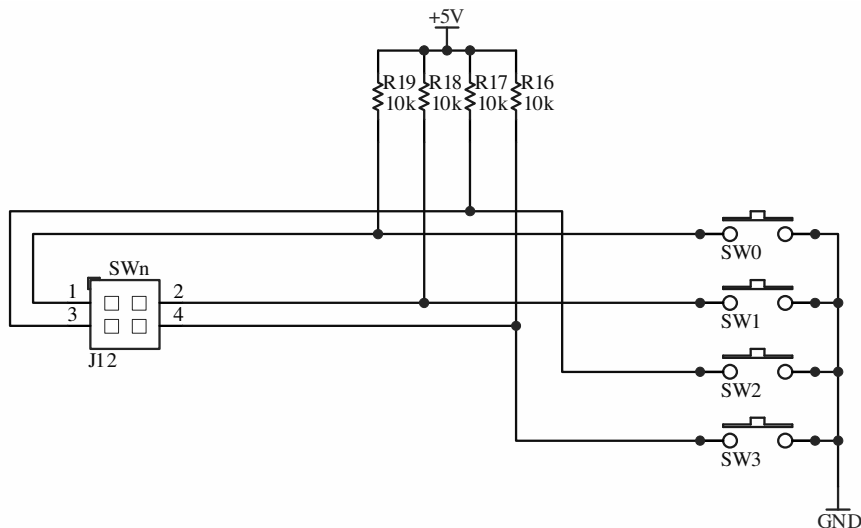

Figure 4 Implementation of push-buttons.

## LCD display

The LCD display is connected to the data bus of the microcontroller. The connection method permits only the write operation to the display, which is, however, sufficient for its operation. The SEL1 output should be configured as a write strobe. The display is seen in the address space from 0xFF04 to 0xFF05, the choice between the instruction register and the data register of the display is executed by means of the A0 address line:

0xFF04 – instruction register  
0xFF05 – data register

The contrast voltage of the LCD is set by the voltage divider R4 and R5.

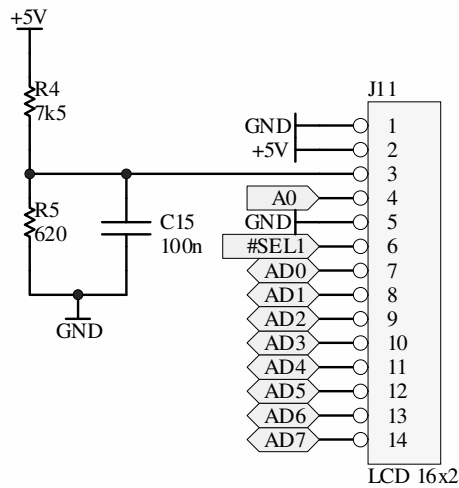

**Figure 5** Connection of the LCD display to the microcontroller bus.

## Potentiometers

EVBnet02 has two potentiometers, POT0 and POT1. The potentiometers can be used to simulate the outputs of analog circuits. The voltage across POTx terminals can be adjusted in the 0....REF range.

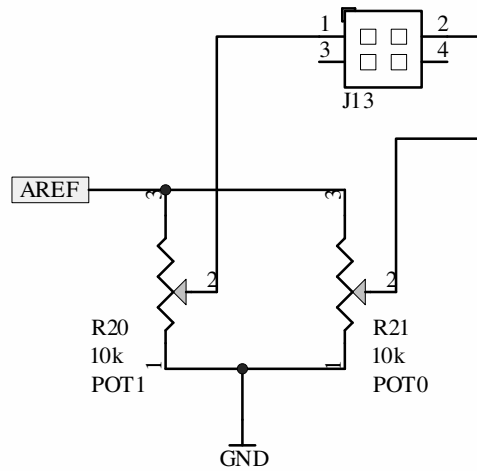
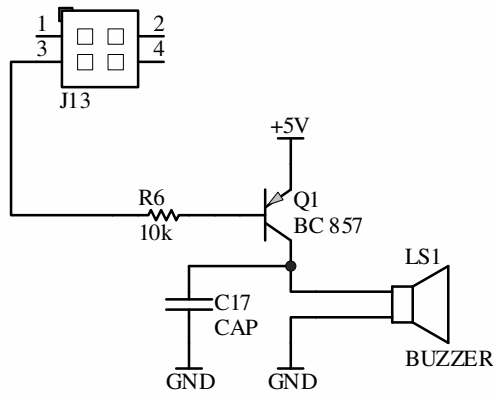

**Figure 6** Implementation of potentiometers.

## Buzzer

The board has a built-in acoustic signaler, controlled by a logic low state through a transistor. The base of the transistor is connected to connector J13 as SPK.

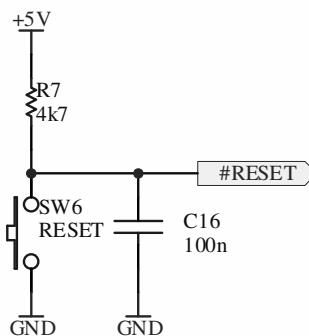



**Figure 7** Implementation of the Buzzer

## RESET button

The MMnet02 board has a led-out RESET signal which can be used as the output to reset external circuits and as the input to reset the module, e.g. through the RESET push-button. The EVBnet02 board is equipped with an on-board resetting button; by pressing it we force a low state on the RESET terminal of the module.

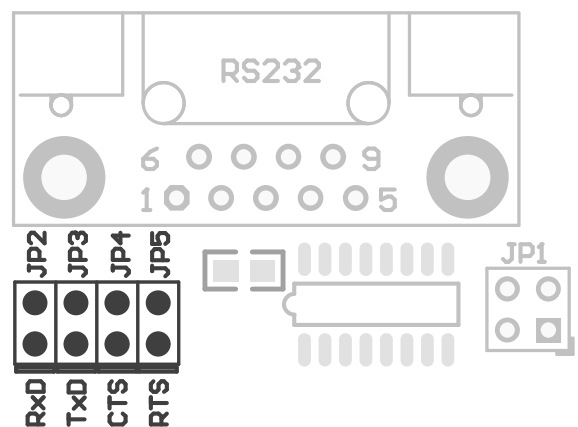

**Figure 8** Implementation of the RESET push-button.

## RS-232 interface

The EVBnet02 board has one port for serial RS232 transmission with a DB-9 connector. The lead-outs TxD, RxD, RTS, CTS are applied to the jumpers through a MAX232 level converter. The DSR and DTR signals have been shorted.

Applying jumpers causes the connection of TxD and RxD to the USART0 port of the microcontroller and of CTS and RTS signals to line PE2 and PE3, respectively. Signals of the RS232 port can be connected also to any lead-outs of the microcontroller by means of cables.



Attention: if flow control has not been implemented, signals CTS and RTS should be connected to each other by means of a jumpers (as shown in the figure) in order to assure proper communication.

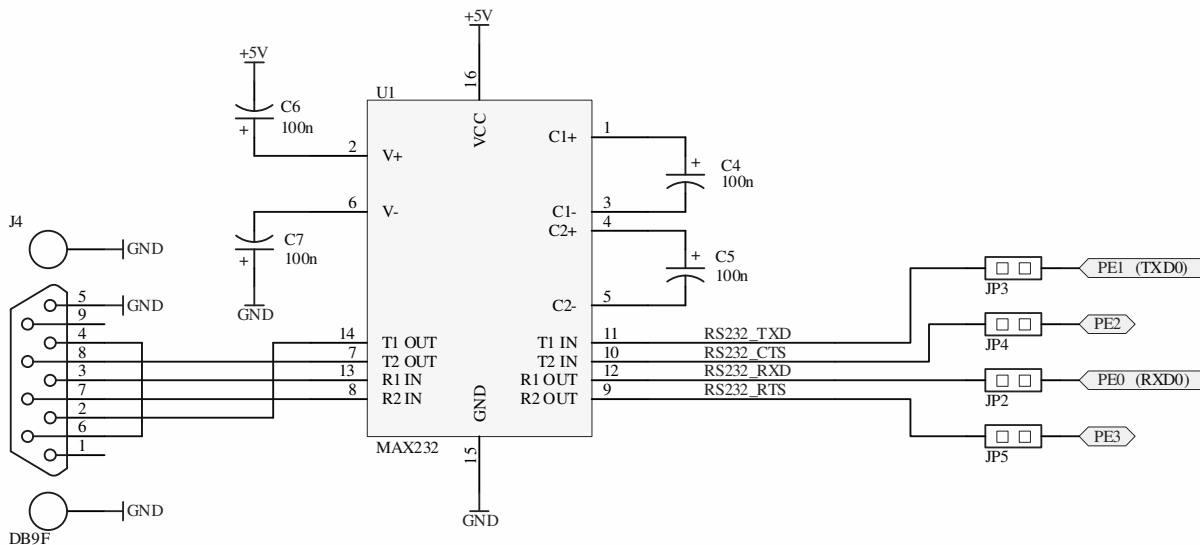
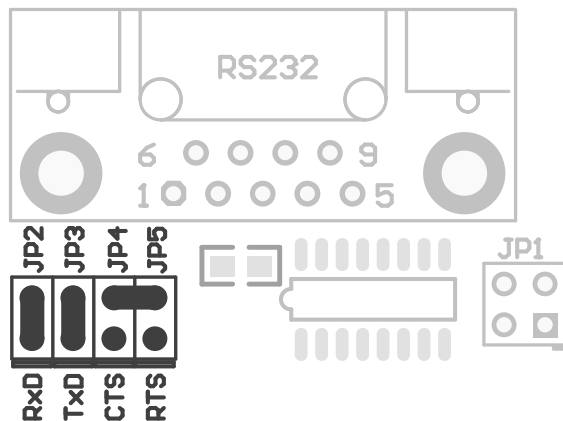

Figure 9 Connection of the RS-232 port to the MMnet02 board.

## 1-Wire Interface

The EVBnet02 board has a 1-Wire bus connector. This connector can be used to connect e.g. a digital DS1820 thermometer or Dallas/Maxim iButton reader from. The data signal has been applied to the J13 connector and designated as 1-W. It can be connected to any microcontroller lead-out by means of the attached cable.

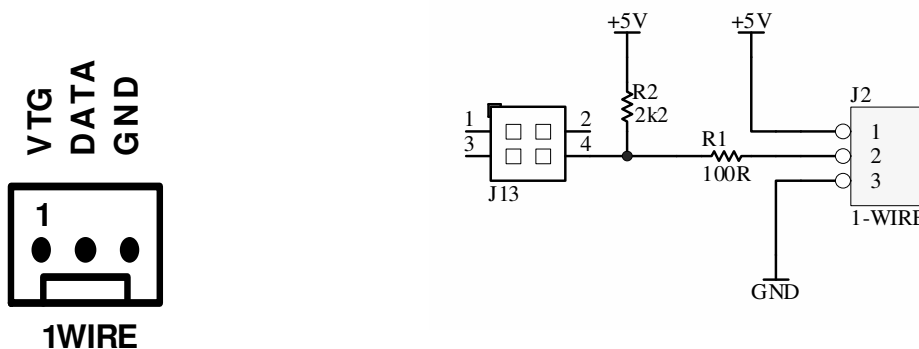
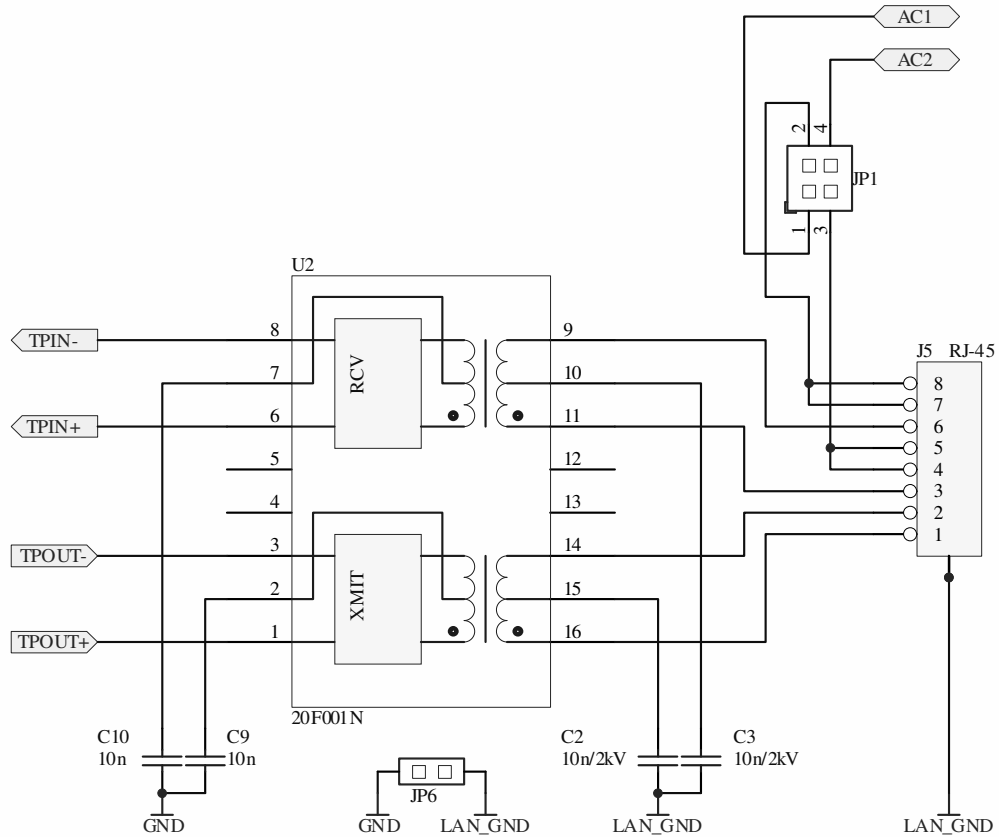

Figure 10 Connection of the 1-Wire connector.

## Connection to the Ethernet network

The EVBnet02 board has an Ethernet RJ-45 socket. The lead-outs of the RJ-45 are connected with the Ethernet RTL8019AS controller through a 10Base-T transformer. The maximum cable length between the EVBnet02 board and the hub/switch is 100 meters.



**Figure 11** Connection to the Ethernet through a transformer.

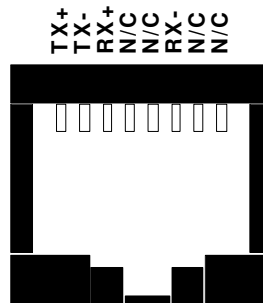

**Figure 12** RJ-45 connector pin description.

## ISP and JTAG connectors

Programming of the module can be effected through the ISP or JTAG interfaces (the second one permits also debugging in the system).

The ISP standard programmer communicates with the microcontroller through a three-wire SPI interface (plus the RESET signal and power supply). The interface uses the I/O pins of the microcontroller (PE0, PE1 and PB1) which, after programming, can perform usual functions. The LED signal controls the operation of multiplexer U3 which disconnects, for the duration of the programming session, the ISP bus lines from the peripheral circuits of the board, thus eliminating the possibility of an accidental writing operation into these circuits. During the writing operation this line should be in the low state. The JP7 short allows manual control of the multiplexer in case of using a programmer which is not serving this line.

JTAG is a four-lead interface permitting the takeover of control over the processor's core and its internal peripherals. The possibilities offered by this interface are, among others: step operation, full-speed operation, equipment and program pitfalls, inspection and modification of contents of registers and data memories. Apart from this, functions are available offered by ISP programmers: programming and readout of Flash, EEPROM, fuse and lock bits.

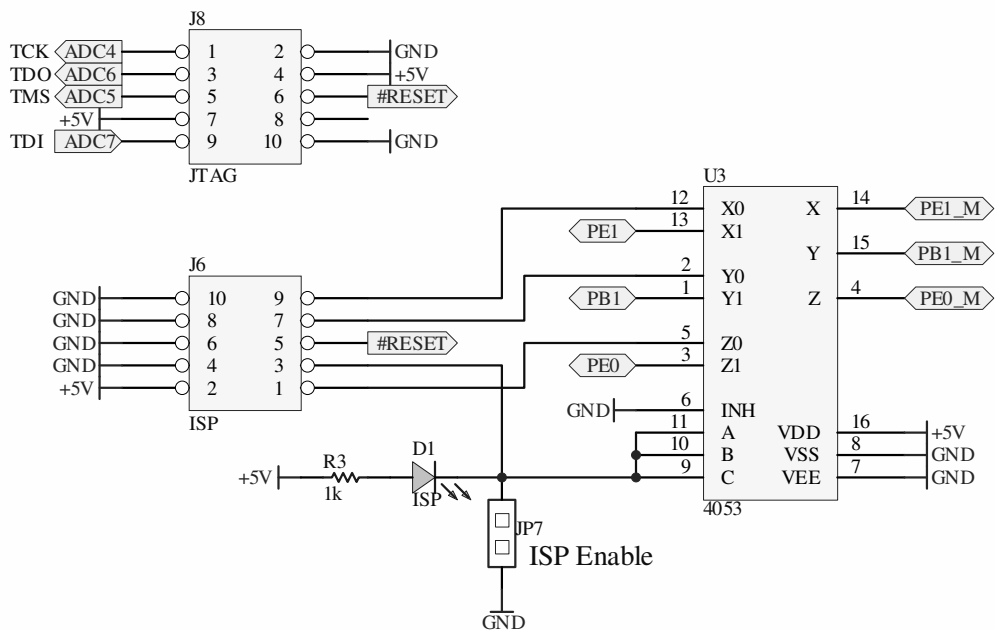

Figure 13 Connection of the MMnet02 module with the JTAG connector.

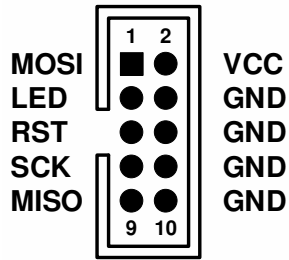

Figure 14 ISP connector.

Pin description	
<b>MOSI</b>	Commands and data from programmer to target
<b>LED</b>	Multiplexer and LED diode driving signal
<b>RST</b>	RESET signal
<b>SCK</b>	Serial Clock, Controlled by programmer
<b>MISO</b>	Data from target AVR to programmer
<b>VCC</b>	Supply voltage to the programmer
<b>GND</b>	Ground

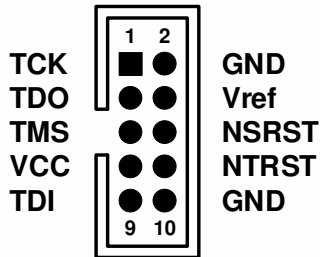

Figure 15 JTAG connector.

Pin description	
<b>TCK</b>	Test Clock, clock signal from emulator to target
<b>TDO</b>	Test Data Output, data signal from target to emul.
<b>TMS</b>	Test Mode Select, mode select signal from emulator to target
<b>VCC</b>	Supply voltage to the emulator
<b>TDI</b>	Test Data Input, data signal from emul. to target
<b>Vref</b>	Target voltage sense
<b>RST</b>	RESET signal
<b>GND</b>	Ground

Programmiers which may be used with EVBnet02 and MMnet02 may be found on pages:

- ISPCable I: [http://www.propox.com/products/t\\_77.html?lang=en](http://www.propox.com/products/t_77.html?lang=en)
- ISPCable II: [http://www.propox.com/products/t\\_78.html?lang=en](http://www.propox.com/products/t_78.html?lang=en)

JTAG programmer/emulator may be found on page:

- JTAGCable I: [http://www.propox.com/products/t\\_99.html?lang=en](http://www.propox.com/products/t_99.html?lang=en)

### 3 Technical assistance

In order to obtain technical assistance please contact [support@propox.com](mailto:support@propox.com) . In the request please include the following information:

- Number of the board version (e.g. REV 2)
- Setting of resistors
- A detailed description of the problem

### 4 Guarantee

The MMnet02 minimodule is covered by a six-month guarantee. All faults and defects not caused by the user will be removed at the Producer's cost. Transportation costs are borne by the buyer.

The Producer takes no responsibility for any damage and defects caused in the course of using the MMnet02 module.

# 5 Board layout and dimensions

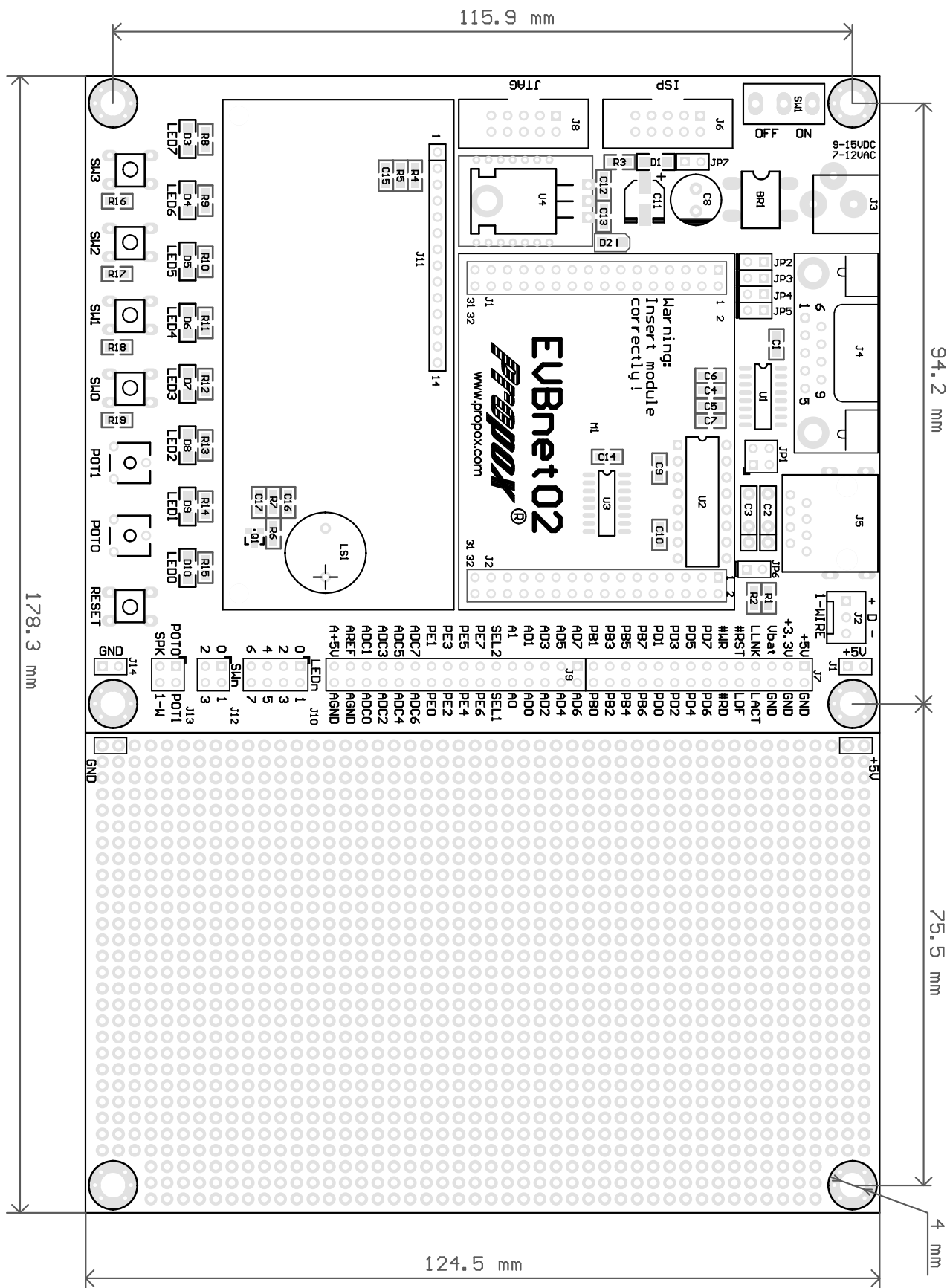

# 6 Schematics

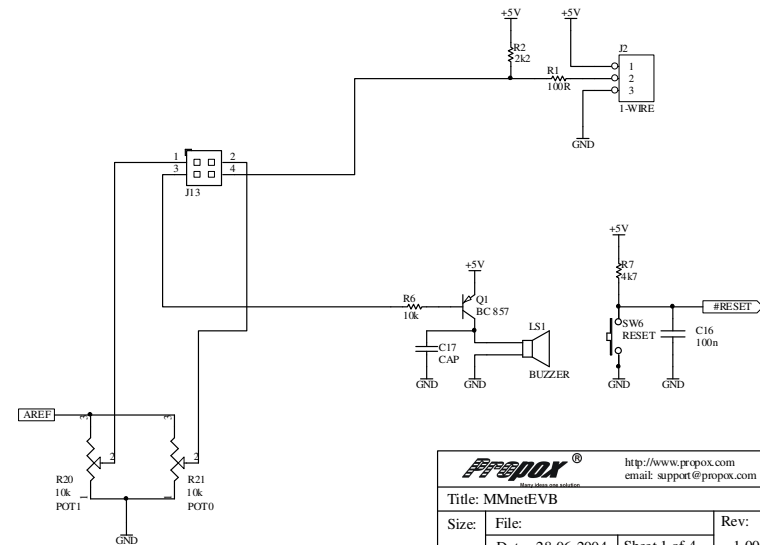
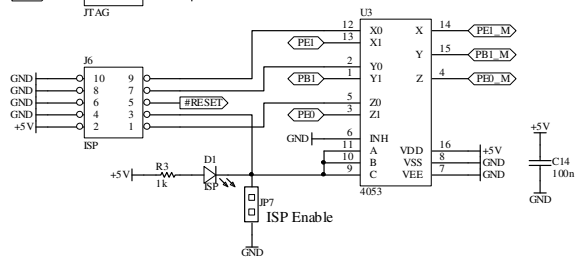
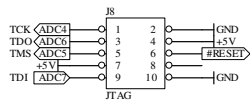
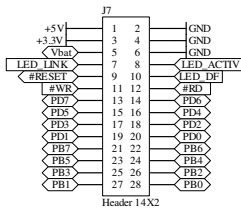
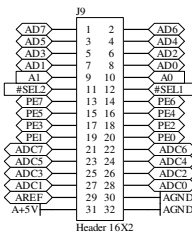
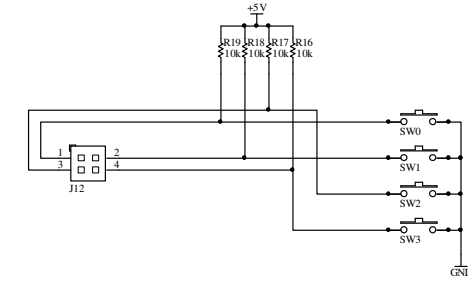
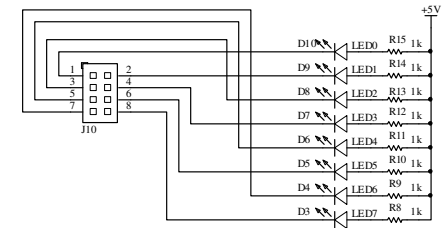
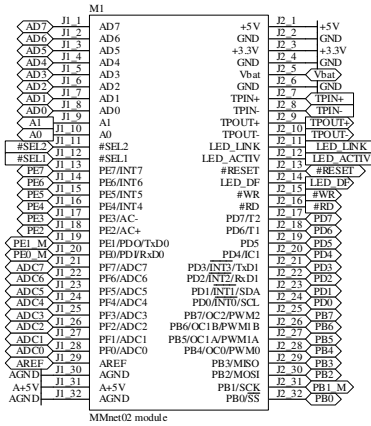
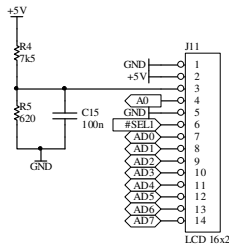

<b>PROPPOX</b>		http://www.propox.com	
		email: support@propox.com	
Title: MMnetEVB			
Size:	File:	Rev:	
Date: 28-06-2004		Sheet 1 of 4	1.00

**RS-232**

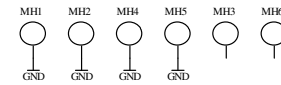
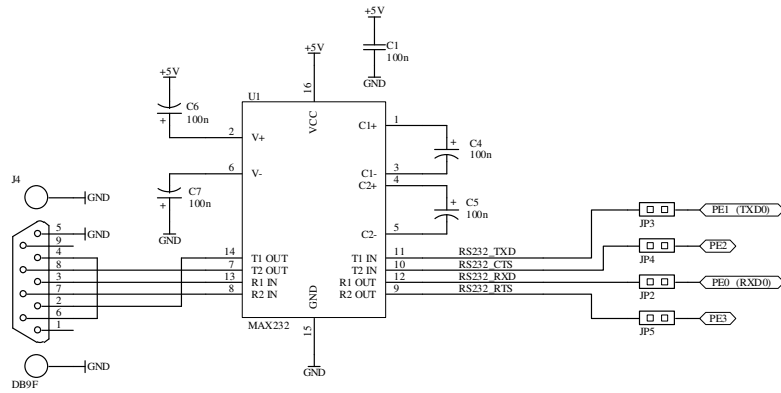

**POWER**

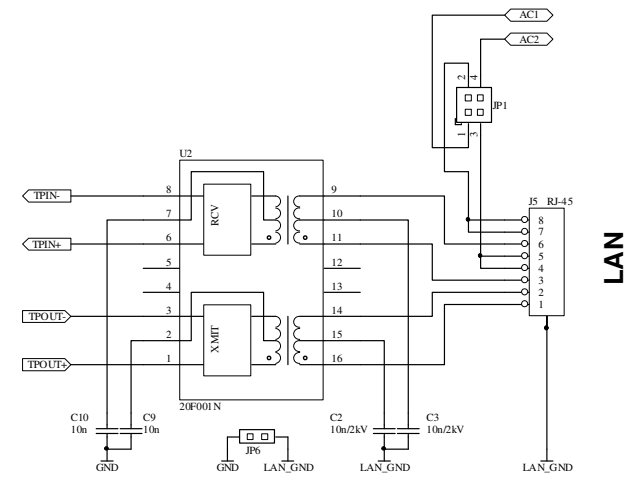
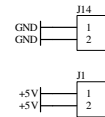
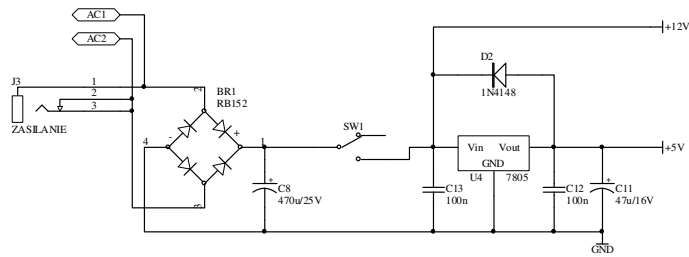

<b>PROPPOX</b> ®		http://www.propox.com email: support@propox.com	
Title: MMnetEVB			
Size:	File:	Rev:	
Date: 28-06-2004	Sheet 2 of 4	1.00	