

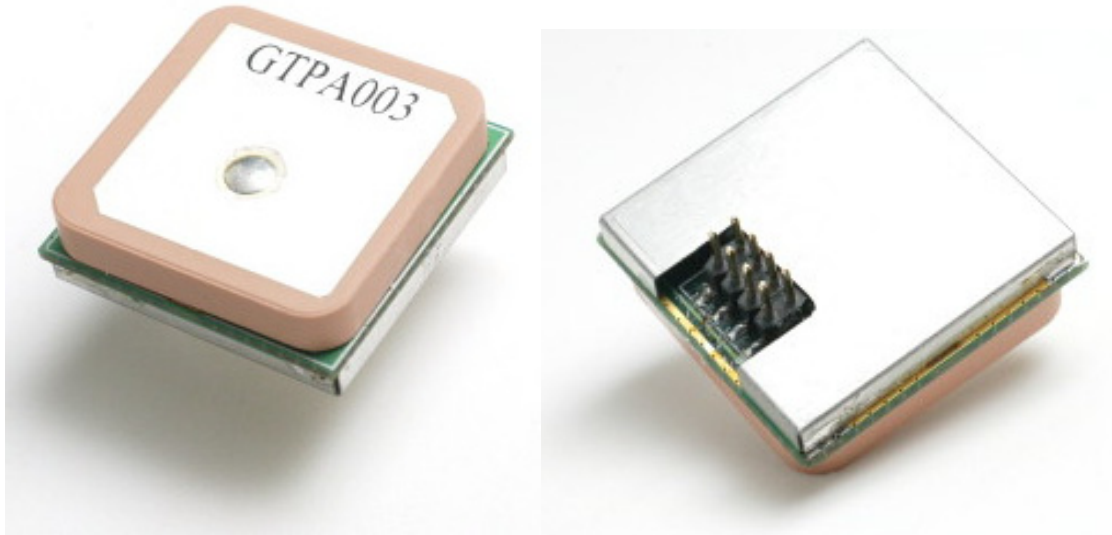

FGPMMOPA4 Datasheet

Rev.A02



32-channel GPS Engine Board SmartAntenna

with MTK Chipset

FGPMMOPA4

The document is the exclusive property of GlobalTop Tech Inc. and should not be distributed, reproduced, or any other format without prior permission of GlobalTop Tech Inc. Specifications subject to change without prior notice

GlobalTop Tech Inc.

16 Nan-ke 9th Rd Science-based Industrial Park, Tainan 741, Taiwan, R.O.C.
Tel:+886-6-6007799 Fax:+886-6-5053381 <http://www.gtop-tech.com/> email: sales@gtop-tech.com
Copyright© 2006 GlobalTop Tech Inc. All right reserved.



FGPMMOPA4 Datasheet

Rev.A02

History		
Date	Rev.	Description
2008/05/22	A00	First Release
2008/08/14	A01	Add Appendix A: Add connector information
2008/12/15	A02	Page 11 Modify Operating Temperature Range

The document is the exclusive property of GlobalTop Tech Inc. and should not be distributed, reproduced, or any other format without prior permission of GlobalTop Tech Inc. Specifications subject to change without prior notice

GlobalTop Tech Inc.

16 Nan-ke 9th Rd Science-based Industrial Park, Tainan 741, Taiwan, R.O.C.
Tel:+886-6-6007799 Fax:+886-6-5053381 <http://www.gtop-tech.com/> email: sales@gtop-tech.com
Copyright© 2006 GlobalTop Tech Inc. All right reserved.



FGPMMOPA4 Datasheet

Rev.A02

Description

The FGPMMOPA4 is a POT (Patch On Top) GPS the third generation module. This POT GPS receiver providing a solution that high position and speed accuracy performances as well as high sensitivity and tracking capabilities in urban conditions. The GPS chipsets inside the module are designed by MediaTek Inc., which is the world's leading digital media solution provider and largest fab-less IC company in Taiwan. The module can support up to 32 channels. The GPS solution enables small form factor devices. They deliver major advancements in GPS performances, accuracy, integration, computing power and flexibility. They are designed to simplify the embedded system integration process.

FGPMMOPA4 Features

- ✚ Based on MediaTek Single Chip Architecture.
- ✚ Dimension : 26mm x 26mm x 11.7mm
- ✚ Patch Antenna Size : 25mm x 25mm x 4mm
- ✚ Low Power Consumption : 55mA @ acquisition, 40mA @ tracking
- ✚ L1 Frequency, C/A code, 32-channel
- ✚ High Sensitivity : Up to -158 dBm tracking, superior urban performances
- ✚ Position Accuracy : < 3m CEP (50%) without SA (horizontal)
- ✚ Cold Start is Under 36 seconds (Typical)
- ✚ Warm Start is Under 34 seconds (Typical)
- ✚ Hot Start is Under 1 second (Typical)
- ✚ Data output Baud rate : 9600 bps
- ✚ Max. Update Rate : 5Hz
- ✚ Pinheader Connection for easy to assemble
- ✚ RoHS Compliant

The document is the exclusive property of GlobalTop Tech Inc. and should not be distributed, reproduced, or any other format without prior permission of GlobalTop Tech Inc. Specifications subject to change without prior notice

GlobalTop Tech Inc.

16 Nan-ke 9th Rd Science-based Industrial Park, Tainan 741, Taiwan, R.O.C.
Tel:+886-6-6007799 Fax:+886-6-5053381 <http://www.gtop-tech.com/> email: sales@gtop-tech.com
Copyright© 2006 GlobalTop Tech Inc. All right reserved.

System Block

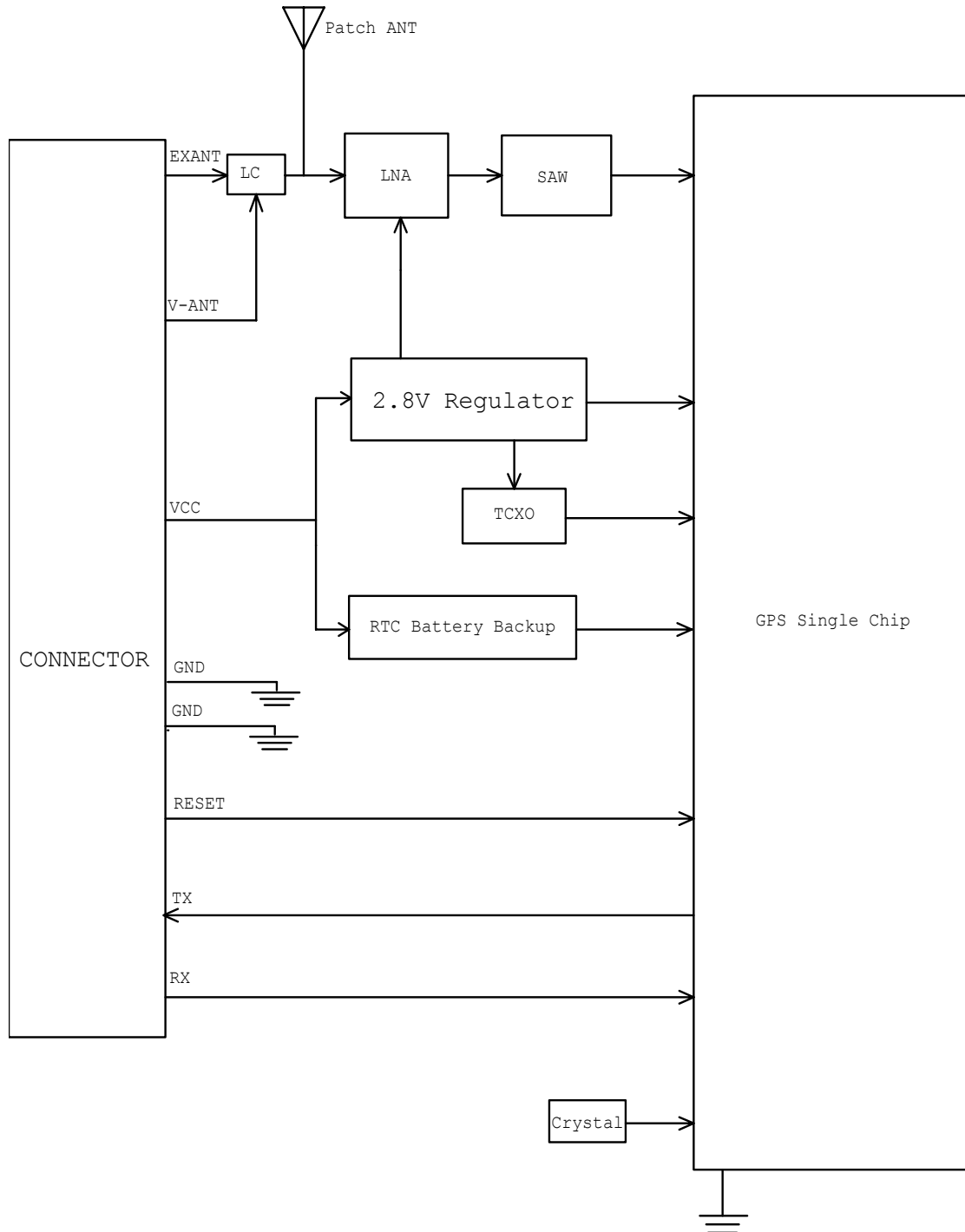

The document is the exclusive property of GlobalTop Tech Inc. and should not be distributed, reproduced, or any other format without prior permission of GlobalTop Tech Inc. Specifications subject to change without prior notice

GlobalTop Tech Inc.

16 Nan-ke 9th Rd Science-based Industrial Park, Tainan 741, Taiwan, R.O.C.
 Tel:+886-6-6007799 Fax:+886-6-5053381 <http://www.gtop-tech.com/> email: sales@gtop-tech.com
 Copyright© 2006 GlobalTop Tech Inc. All right reserved.

Mechanical and Pin Configuration

Item	Model Name	Description
1	FGPMMOPA4	Pin Header, Dual Row, SMT TYPE

1. Model Name: FGPMMOPA4

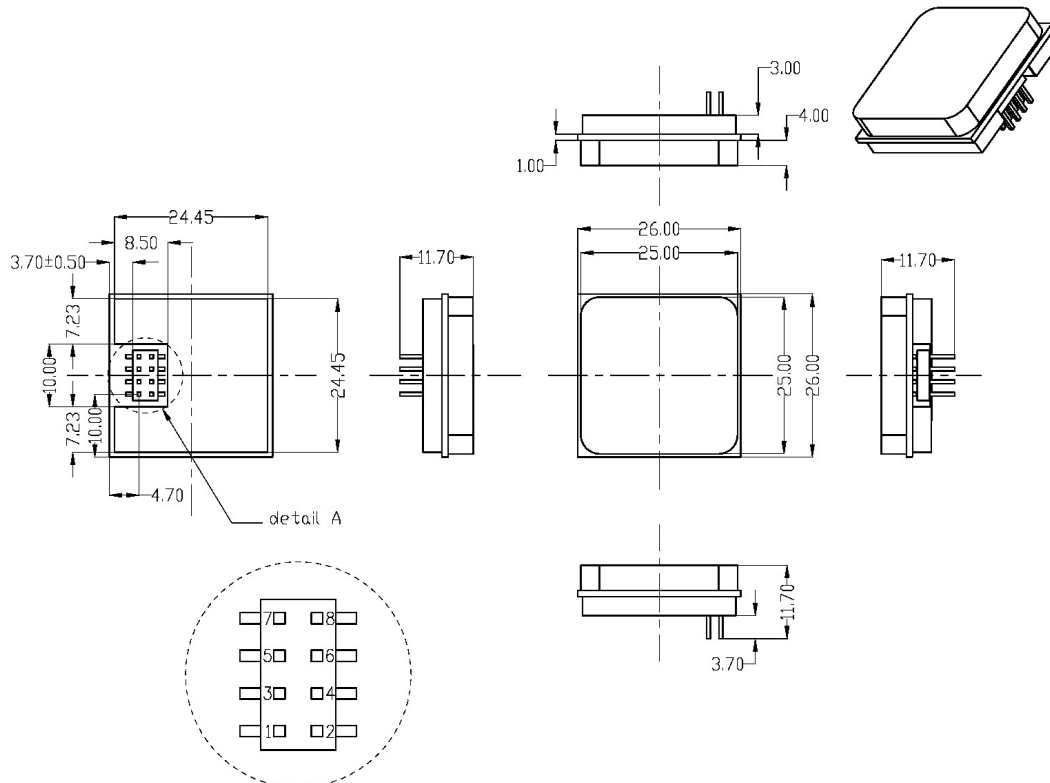

detail A (Please refer to Appendix A)

The document is the exclusive property of GlobalTop Tech Inc. and should not be distributed, reproduced, or any other format without prior permission of GlobalTop Tech Inc. Specifications subject to change without prior notice

GlobalTop Tech Inc.

16 Nan-ke 9th Rd Science-based Industrial Park, Tainan 741, Taiwan, R.O.C.

Tel:+886-6-6007799 Fax:+886-6-5053381 <http://www.gtop-tech.com/> email: sales@gtop-tech.com

Copyright© 2006 GlobalTop Tech Inc. All right reserved.



FGPMMOPA4 Datasheet

Rev.A02

Pin Definition

Pin	Name	I/O	Description
1	VCC	P	DC Power Input
2	GND	P	Ground
3	RX	I	Serial Data Input
4	TX	O	Serial Data Output
5	V-ANT	P	External Antenna power input
6	GND	P	Ground
7	RESET	I	Reset
8	EXANT	I	External Antenna input

Description of I/O Pin

VCC (Pin1)

The main DC power supply is DC 3.3V±5% for the module.

GND (Pin2)

The analog ground and digital ground for the module.

RX (Pin3)

This is the UART receiver of the module. It is used to receive software commands and firmware update.

TX (Pin4)

This is the UART transmitter of the module. It outputs the GPS information for application.

V-ANT (Pin5)

The power supply is DC 2.7V to 3.3V for the External Antenna input pin(Pin8).

GND(Pin6)

The analog ground and digital ground for the module.

RESET(Pin7)

This pin is Reset pin.

EXANT(Pin8)

This pin is External Antenna input pin.

The document is the exclusive property of GlobalTop Tech Inc. and should not be distributed, reproduced, or any other format without prior permission of GlobalTop Tech Inc. Specifications subject to change without prior notice

GlobalTop Tech Inc.

16 Nan-ke 9th Rd Science-based Industrial Park, Tainan 741, Taiwan, R.O.C.
Tel:+886-6-6007799 Fax:+886-6-5053381 <http://www.gtop-tech.com/> email: sales@gtop-tech.com
Copyright© 2006 GlobalTop Tech Inc. All right reserved.



FGPMMOPA4 Datasheet

Rev.A02

Specifications

General	
Chipset	MTK MT3318
Frequency	L1, 1575.42MHz
C/A Code	1.023 MHz
Channels	32 channels
DGPS	RTCM protocol WAAS, EGNOS, MSAS
Datum	WGS84(Default), Tokyo-M, Tokyo-A, User Define
CPU	ARM7TDMI
Dimensions	
Length/Width/Height	26mm x26mm x 11.7mm
Weight	12.5g
Performance Characteristics	
Position Accuracy	Without aid : 3.0m 2D-RMS
	< 3m CEP (50%) without SA (horizontal)
	DGPS (RTCM, SBAS (WAAS, EGNOS, MSAS)) : 2.5m
Velocity Accuracy	Without aid : 0.1 m/s
	DGPS (RTCM, SBAS (WAAS, EGNOS, MSAS)) : 0.05m/s
Acceleration	Without aid : < 4g
	DGPS (RTCM, SBAS (WAAS, EGNOS, MSAS)) : < 4g
Timing Accuracy	100 ns RMS
Sensitivity	Acquisition : -146dBm (Cold Start)
	Reacquisition : -156dBm
	Tracking : -158dBm
Max. Update Rate	5Hz
Acquisition (Open sky, stationary)	
Reacquisition Time	Less than 1 second
Hot start	1 second (Typical)

The document is the exclusive property of GlobalTop Tech Inc. and should not be distributed, reproduced, or any other format without prior permission of GlobalTop Tech Inc. Specifications subject to change without prior notice

GlobalTop Tech Inc.

16 Nan-ke 9th Rd Science-based Industrial Park, Tainan 741, Taiwan, R.O.C.
 Tel:+886-6-6007799 Fax:+886-6-5053381 <http://www.gtop-tech.com/> email: sales@gtop-tech.com
 Copyright© 2006 GlobalTop Tech Inc. All right reserved.



FGPMMOPA4 Datasheet

Rev.A02

Warm start	34seconds (Typical)
Cold start	36 seconds (Typical)
Dynamic	
Altitude	Maximum 18,000m
Velocity	Maximum 515m/s
Acceleration	Maximum 4g
I/O	
Signal Output	8 data bits, no parity, 1 stop bit
Available Baud Rates	4800/9600/14400/19200/38400/57600/115200 is also available
Protocols	NMEA 0183 v3.01 (Default : GGA,GSA,GSV,RMC,VTG) RTCM MTK NMEA Command Network Assistance Messages
Data output Interface	
Protocol messages	9600 bps/8/N/1 (Default)
Output format	GGA(1sec),GSA(1sec),RMC(1sec),VTG(1sec), GSV(5sec) (Default)
Environment	
Operating Temperature	-40°C to 85 °C (without coin battery) -20°C to 60 °C (with coin battery)
Storage Temperature	-50°C to 90 °C (without coin battery) -20°C to 60 °C (with coin battery)
Operating Humidity	5% to 95% (no condensing)

The document is the exclusive property of GlobalTop Tech Inc. and should not be distributed, reproduced, or any other format without prior permission of GlobalTop Tech Inc. Specifications subject to change without prior notice

GlobalTop Tech Inc.

16 Nan-ke 9th Rd Science-based Industrial Park, Tainan 741, Taiwan, R.O.C.
Tel:+886-6-6007799 Fax:+886-6-5053381 <http://www.gtop-tech.com/> email: sales@gtop-tech.com
Copyright© 2006 GlobalTop Tech Inc. All right reserved.



FGPMMOPA4 Datasheet

Rev.A02

Recommendation External Antenna Specification

MODEL: FGPANExxxxx	
Center Frequency fo	1575.42MHz \pm 2MHz
Bandwidth (min.)	9MHz
Operating Temperature	-40 ~ +85°C
Storage Temperature	-50 ~ +120°C
Relative Humidity	0% ~ 100%
Antenna + Pre-amplifier:	
System Gain at fo Without Cable Loss	30dBi at 90° Zenith
Output VSWR at fo (max.)	2
Impedance (typ.)	50ohm
Cable Loss RG-174/3,5,10meters at fo (typ.)	4dB, 7dB, 14dB
Mounting	Magnet
Patch Antenna:	
Polarization	R.H.C.P.
Gain at fo (typ.)	3dBi at Zenith
VSWR at fo (max.)	2
Impedance (typ.)	50ohm
Pre-amplifier:	
Gain at fo	27dB \pm 1dB
Noise Figure at fo (typ.)	1.15dB
VSWR at fo (max.)	2
Impedance (typ.)	50ohm
Input Voltage	2.7V ~ 3.6V
Current Consumption (typ.)	18mA@3V
Test Environment Condition : 25°C/60RH	

The document is the exclusive property of GlobalTop Tech Inc. and should not be distributed, reproduced, or any other format without prior permission of GlobalTop Tech Inc. Specifications subject to change without prior notice

GlobalTop Tech Inc.

16 Nan-ke 9th Rd Science-based Industrial Park, Tainan 741, Taiwan, R.O.C.
Tel:+886-6-6007799 Fax:+886-6-5053381 <http://www.gtop-tech.com/> email: sales@gtop-tech.com
Copyright© 2006 GlobalTop Tech Inc. All right reserved.



FGPMMOPA4 Datasheet

Rev.A02

DC Characteristics

Parameter	Condition	Min.	Typ.	Max.	Unit
Operation supply Voltage	VCC	3.135	3.3	3.465	V
Operation supply Ripple Voltage	—	—	—	50	mVpp
RXA TTL H Level	VCC=5.0V	2.1	—	VCC	V
RXA TTL L Level	VCC=5.0V	0	—	0.9	V
TXA TTL H Level	VCC=5.0V	2.1	—	2.8	V
TXA TTL L Level	VCC=5.0V	0	—	0.8	V
Backup Battery Voltage	—	—	3.0	—	V
Power Consumption @ 3.3V	Acquisition	50	55	60	mA
	Tracking	35	40	45	mA

The document is the exclusive property of GlobalTop Tech Inc. and should not be distributed, reproduced, or any other format without prior permission of GlobalTop Tech Inc. Specifications subject to change without prior notice

GlobalTop Tech Inc.

16 Nan-ke 9th Rd Science-based Industrial Park, Tainan 741, Taiwan, R.O.C.
Tel:+886-6-6007799 Fax:+886-6-5053381 <http://www.gtop-tech.com/> email: sales@gtop-tech.com
Copyright© 2006 GlobalTop Tech Inc. All right reserved.



FGPMMOPA4 Datasheet

Rev.A02

NMEA Output Sentence

Table-1 lists each of the NMEA output sentences specifically developed and defined by MTK for use within MTK products

NMEA Output Sentence		Table-1
Option	Description	
GGA	Time, position and fix type data.	
GSA	GPS receiver operating mode, active satellites used in the position solution, and DOP values.	
GSV	The number of GPS satellites in view satellite ID numbers, elevation, azimuth, and SNR values.	
RMC	Time, date, position, course and speed data. Recommended Minimum Navigation Information.	
VTG	Course and speed information relative to the ground.	

GGA—Global Positioning System Fixed Data. Time, Position and fix related data for a GPS receiver

Table-2 contains the values for the following example :

\$GPGGA,035238.000,2307.1219,N,12016.4423,E,1,9,0.89,23.6,M,17.8,M,,*69

GGA Data Format				Table-2
Name	Example	Units	Description	
Message ID	\$GPGGA		GGA protocol header	
UTC Time	035238.000		hhmmss.sss	
Latitude	2307.1219		ddmm.mmmm	
N/S Indicator	N		N=north or S=south	
Longitude	12016.4424		dddmm.mmmm	
E/W Indicator	E		E=east or W=west	
Satellites Used	9		Range 0 to 14	
HDOP	0.89		Horizontal Dilution of Precision	
MSL Altitude	17.3	meters	Antenna Altitude	

The document is the exclusive property of GlobalTop Tech Inc. and should not be distributed, reproduced, or any other format without prior permission of GlobalTop Tech Inc. Specifications subject to change without prior notice

GlobalTop Tech Inc.

16 Nan-ke 9th Rd Science-based Industrial Park, Tainan 741, Taiwan, R.O.C.
Tel:+886-6-6007799 Fax:+886-6-5053381 <http://www.gtop-tech.com/> email: sales@gtop-tech.com
Copyright© 2006 GlobalTop Tech Inc. All right reserved.



FGPMMOPA4 Datasheet

Rev.A02

			above/below mean-sae-level
Units	M	meters	Units of antenna altitude
Geoidal Separation	17.8	meters	
Units	M	meters	Units of geoidal separation
Age of Diff. Corr.		second	Null fields when DGPS is not used
Checksum	*69		
<CR> <LF>			End of message termination

GSA—GNSS DOP and Active Satellites

Table-3 contains the values for the following example :

\$GPGSA,A,3,29,21,09,18,10,26,12,24,15,,1.20,0.89,0.80*04

GSA Data Format			Table-3
Name	Example	Units	Description
Message ID	\$GPGSA		GSA protocol header
Mode 1	A		See Table-4
Mode 2	3		See Table-5
Satellite Used	29		SV on Channel 1
Satellite Used	21		SV on Channel 2
....
Satellite Used			SV on Channel 12
PDOP	1.20		Position Dilution of Precision
HDOP	0.89		Horizontal Dilution of Precision
VDOP	0.80		Vertical Dilution of Precision
Checksum	*04		
<CR> <LF>			End of message termination

Mode 1		Table-4
Value	Description	
M	Manual—forced to operate in 2D or 3D mode	
A	2D Automatic—allowed to automatically switch 2D/3D	

The document is the exclusive property of GlobalTop Tech Inc. and should not be distributed, reproduced, or any other format without prior permission of GlobalTop Tech Inc. Specifications subject to change without prior notice

GlobalTop Tech Inc.

16 Nan-ke 9th Rd Science-based Industrial Park, Tainan 741, Taiwan, R.O.C.
 Tel:+886-6-6007799 Fax:+886-6-5053381 <http://www.gtop-tech.com/> email: sales@gtop-tech.com
 Copyright© 2006 GlobalTop Tech Inc. All right reserved.



FGPMMOPA4 Datasheet

Rev.A02

Mode 2		Table-5
Value	Description	
1	Fix not available	
2	2D (< 4 SVs used)	
3	3D (\geq 4 SVs used)	

GSV—GNSS Satellites in View

Table-7 contains the values for the following example :

\$GPGSV,3,1,10,24,76,195,48,09,62,173,48,21,50,308,48,15,45,021,48*73

\$GPGSV,3,2,10,26,33,031,46,18,29,319,46,10,21,092,45,29,18,221,44*7D

\$GPGSV,3,3,10,12,05,167,24,05,03,181,*76

GSV Data Format				Table-6
Name	Example	Units	Description	
Message ID	\$GPGSV		GSV protocol header	
Number of Messages	3		Range 1 to 3 <i>(Depending on the number of satellites tracked, multiple messages of GSV data may be required.)</i>	
Message Number1	1		Range 1 to 3	
Satellites in View	10			
Satellite ID	24		Channel 1 (Range 1 to 32)	
Elevation	76	degrees	Channel 1 (Maximum 90)	
Azimuth	195	degrees	Channel 1 (True, Range 0 to 359)	
SNR (C/No)	48	dBHz	Range 0 to 99, (null when not tracking)	
....	
Satellite ID	15		Channel 4 (Range 1 to 32)	
Elevation	45	degrees	Channel 4 (Maximum 90)	
Azimuth	021	degrees	Channel 4 (True, Range 0 to	

The document is the exclusive property of GlobalTop Tech Inc. and should not be distributed, reproduced, or any other format without prior permission of GlobalTop Tech Inc. Specifications subject to change without prior notice

GlobalTop Tech Inc.

16 Nan-ke 9th Rd Science-based Industrial Park, Tainan 741, Taiwan, R.O.C.
Tel:+886-6-6007799 Fax:+886-6-5053381 <http://www.gtop-tech.com/> email: sales@gtop-tech.com
Copyright© 2006 GlobalTop Tech Inc. All right reserved.



FGPMMOPA4 Datasheet

Rev.A02

			359)
SNR (C/No)	48	dBHz	Range 0 to 99, (null when not tracking)
Checksum	*73		
<CR> <LF>			End of message termination

RMC—Recommended Minimum Navigation Information

Table-7 contains the values for the following example :

\$GPRMC,035242.000,A,2307.1220,N,12016.4420,E,0.06,0.00,140508,,A*63

RMC Data Format			Table-7
Name	Example	Units	Description
Message ID	\$GPRMC		RMC protocol header
UTC Time	035242.000		hhmmss.sss
Status	A		A=data valid or V=data not valid
Latitude	2307.1220		ddmm.mmmm
N/S Indicator	N		N=north or S=south
Longitude	12016.4420		dddmm.mmmm
E/W Indicator	E		E=east or W=west
Speed Over Ground	0.06	knots	
Course Over Ground	0.00	degrees	True
Date	140508		ddmmyy
Magnetic Variation		degrees	E=east or W=west (MTK does support magnetic declination)
Mode	A		A= Autonomous mode D= Differential mode E= Estimated mode
Checksum	*63		
<CR> <LF>			End of message termination

The document is the exclusive property of GlobalTop Tech Inc. and should not be distributed, reproduced, or any other format without prior permission of GlobalTop Tech Inc. Specifications subject to change without prior notice

GlobalTop Tech Inc.

16 Nan-ke 9th Rd Science-based Industrial Park, Tainan 741, Taiwan, R.O.C.
Tel:+886-6-6007799 Fax:+886-6-5053381 <http://www.gtop-tech.com/> email: sales@gtop-tech.com
Copyright© 2006 GlobalTop Tech Inc. All right reserved.



FGPMMOPA4 Datasheet

Rev.A02

VTG—Course and speed information relative to the ground.

Table-8 contains the values for the following example :

\$GPVTG,0.00,T,,M,0.06,N,0.11,K,A*3B

VTG Data Format			Table-8
Name	Example	Units	Description
Message ID	\$GPVTG		VTG protocol header
Course	0.00	degrees	Measured heading
Reference	T		True
Course		degrees	Measured heading
Reference	M		Magnetic <i>(MTK does not support magnetic declination.)</i>
Speed	0.06	knots	Measured horizontal speed
Units	N		Knots
Speed	0.11	km/hr	Measured horizontal speed
Units	K		Kilometers per hour
Mode	A		A= Autonomous mode D= Differential mode E= Estimated mode
Checksum	*3B		
<CR> <LF>			End of message termination

MTK NMEA Command Protocol

Packet Type :

103 PMTK_CMD_COLD_START

Packet Meaning :

Cold Start : Don't use Time, Position, Almanacs and Ephemeris data at re-start.

Example :

\$PMTK103*30<CR><LF>

The document is the exclusive property of GlobalTop Tech Inc. and should not be distributed, reproduced, or any other format without prior permission of GlobalTop Tech Inc. Specifications subject to change without prior notice

GlobalTop Tech Inc.

16 Nan-ke 9th Rd Science-based Industrial Park, Tainan 741, Taiwan, R.O.C.

Tel:+886-6-6007799 Fax:+886-6-5053381 <http://www.gtop-tech.com/> email: sales@gtop-tech.com

Copyright© 2006 GlobalTop Tech Inc. All right reserved.

Appendix A:

PART NO: PH2M20-204-GB-LF+CAP-T-6.2/4/2.7 Connector

Manufacturer : CHU YUEN ELECTRONIC CO., LTD.

E-mail : chu.yuen@msa.hinet.net

Ps. The module use 4 contacts per row.

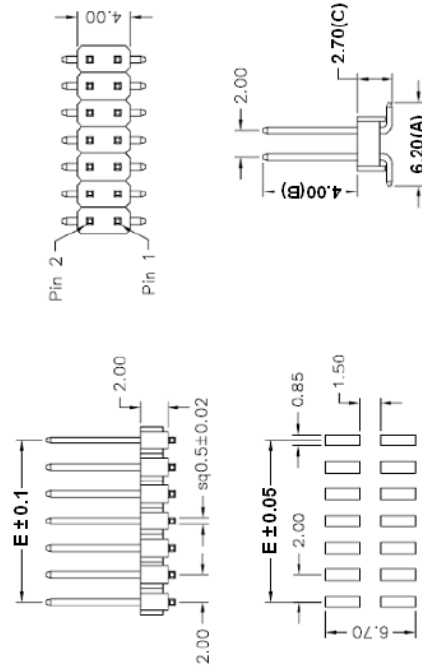

MATERIAL

Contact Pin: Brass

SPECIFICATION

Current Rate: 1 AMP

Insulation Resistance: 5000MΩ Min. at DC 500V

Contact Resistance: 20mΩ Max. at DC 100mA

Dielectric Voltage: AC 500V for one minute

Operation Temperature: - 40°C to + 105°C

PH2M20-204-GB-LF+CAP-T-6.2/4.0/2.7
1 2 3 4 5 6 7 8 9

1. Pitch=2.0 mm
2. M : SMT Type
3. Height=2.0mm
4. No. of contacts per row
5. G : Gold flash
6. B : Black Insulator
7. LF : Lead Free
8. T : 管裝
9. DIM A/B/C=6.2/4.0/2.7

Recommended P.C.B Layout

Poles	DIM E	Poles	DIM E	Poles	DIM E	Poles	DIM E	Poles	DIM E	Poles	DIM E		
2	2.00	9	16.00	16	30.00	23	44.00	30	58.00	37	72.00	44	86.00
3	4.00	10	18.00	17	32.00	24	46.00	31	60.00	38	74.00	45	88.00
4	6.00	11	20.00	18	34.00	25	48.00	32	62.00	39	76.00	46	90.00
5	8.00	12	22.00	19	36.00	26	50.00	33	64.00	40	78.00	47	92.00
6	10.00	13	24.00	20	38.00	27	52.00	34	66.00	41	80.00	48	94.00
7	12.00	14	26.00	21	40.00	28	54.00	35	68.00	42	82.00	49	96.00
8	14.00	15	28.00	22	42.00	29	56.00	36	70.00	43	84.00	50	98.00

The document is the exclusive property of GlobalTop Tech Inc. and should not be distributed, reproduced, or any other format without prior permission of GlobalTop Tech Inc. Specifications subject to change without prior notice

GlobalTop Tech Inc.

16 Nan-ke 9th Rd Science-based Industrial Park, Tainan 741, Taiwan, R.O.C.

Tel:+886-6-6007799 Fax:+886-6-5053381 <http://www.gtop-tech.com/> email: sales@gtop-tech.com

Copyright© 2006 GlobalTop Tech Inc. All right reserved.