

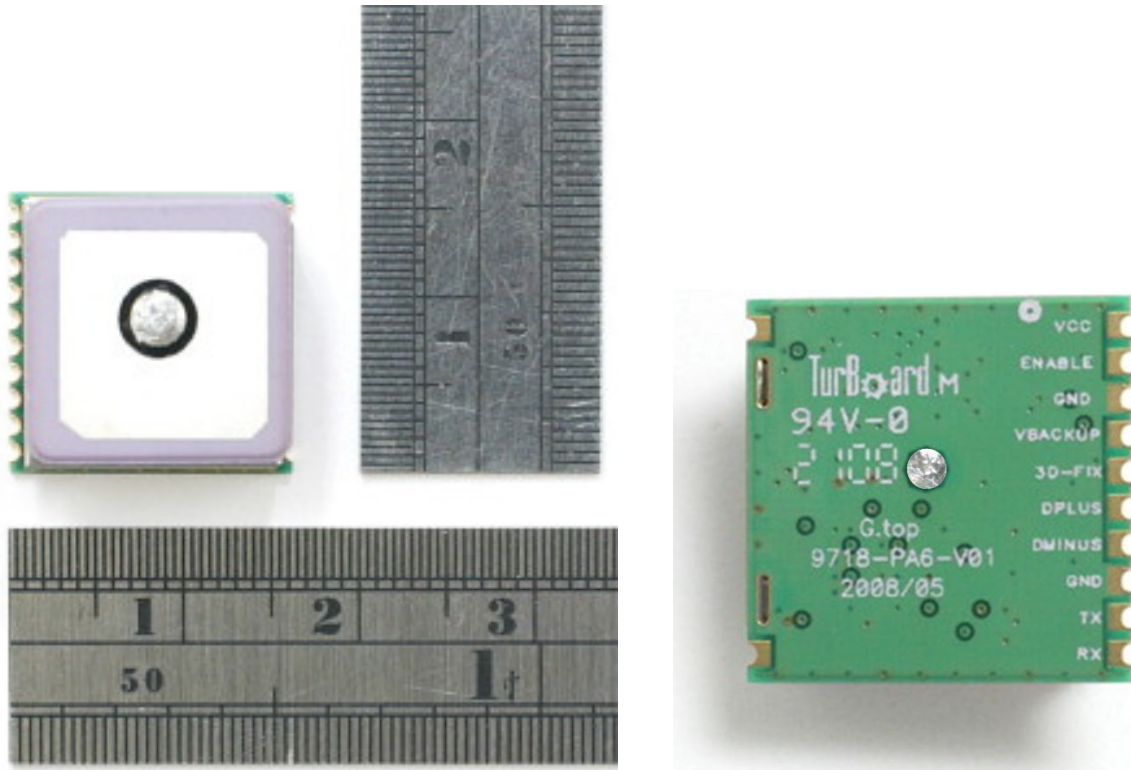

FGPMMOPA6 Datasheet

Rev.A02



66-channel GPS Engine Board SmartAntenna

with MTK Chipset

FGPMMOPA6

The document is the exclusive property of GlobalTop Tech Inc. and should not be distributed, reproduced, or any other format without prior permission of GlobalTop Tech Inc. Specifications subject to change without prior notice

GlobalTop Tech Inc.

16 Nan-ke 9th Rd Science-based Industrial Park, Tainan 741, Taiwan, R.O.C.
Tel:+886-6-6007799 Fax:+886-6-5053381 <http://www.gtop-tech.com/> email: sales@gtop-tech.com
Copyright© 2007 GlobalTop Tech Inc. All right reserved.



FGPMMOPA6 Datasheet

Rev.A02

History		
Date	Rev.	Description
2008/06/26	A00	First Release
2008/10/27	A01	Add more description on I/O pin2 ,pin4
2008/12/15	A02	Page 12 Modify Operating Temperature Range

The document is the exclusive property of GlobalTop Tech Inc. and should not be distributed, reproduced, or any other format without prior permission of GlobalTop Tech Inc. Specifications subject to change without prior notice

GlobalTop Tech Inc.

16 Nan-ke 9th Rd Science-based Industrial Park, Tainan 741, Taiwan, R.O.C.
Tel:+886-6-6007799 Fax:+886-6-5053381 <http://www.gtop-tech.com/> email: sales@gtop-tech.com
Copyright© 2007 GlobalTop Tech Inc. All right reserved.



FGPMMOPA6 Datasheet

Rev.A02

Description

The FGPMMOPA6 is a POT (Patch On Top) GPS Module. This POT GPS receiver providing a solution that high position and speed accuracy performances as well as high sensitivity and tracking capabilities in urban conditions. The GPS chipsets inside the module are powered by MediaTek Inc., which is the world's leading digital media solution provider and largest fab-less IC company in Taiwan. The module can support up to 66 channels. The GPS solution is the small-form-factor ever device.

Features

- MediaTek Single Chip
- Dimension : 16mm x 16mm x 6mm
- Patch Antenna Size : 15mm x 15mm x 4mm
- L1 Frequency, C/A code, 66 channels
- Embedded LNA and SAW filter
- With Active patch antenna
- High Sensitivity : Up to -163 dBm tracking, superior urban performances
- Position Accuracy : < 3m CEP (50%) without SA (horizontal)
- Cold Start is Under 35 seconds (Typical)
- Warm Start is Under 34 seconds (Typical)
- Hot Start is Under 1 second (Typical)
- Low Power Consumption : 48mA @ acquisition, 37mA @ tracking
- Low shut-down current consumption : 15uA, typical
- DGPS(WAAS, EGNOS, MSAS) support (optional by firmware)
- Max. Update Rate : up to 5Hz
- USB/UART Interface
- SMD TYPE
- Support AGPS function (Offline mode : EPO valid up to 14 days)
- RoHS Compliant

The document is the exclusive property of GlobalTop Tech Inc. and should not be distributed, reproduced, or any other format without prior permission of GlobalTop Tech Inc. Specifications subject to change without prior notice

GlobalTop Tech Inc.

16 Nan-ke 9th Rd Science-based Industrial Park, Tainan 741, Taiwan, R.O.C.
Tel:+886-6-6007799 Fax:+886-6-5053381 <http://www.gtop-tech.com/> email: sales@gtop-tech.com
Copyright© 2007 GlobalTop Tech Inc. All right reserved.



FGPMMOPA6 Datasheet

Rev.A02

System Block

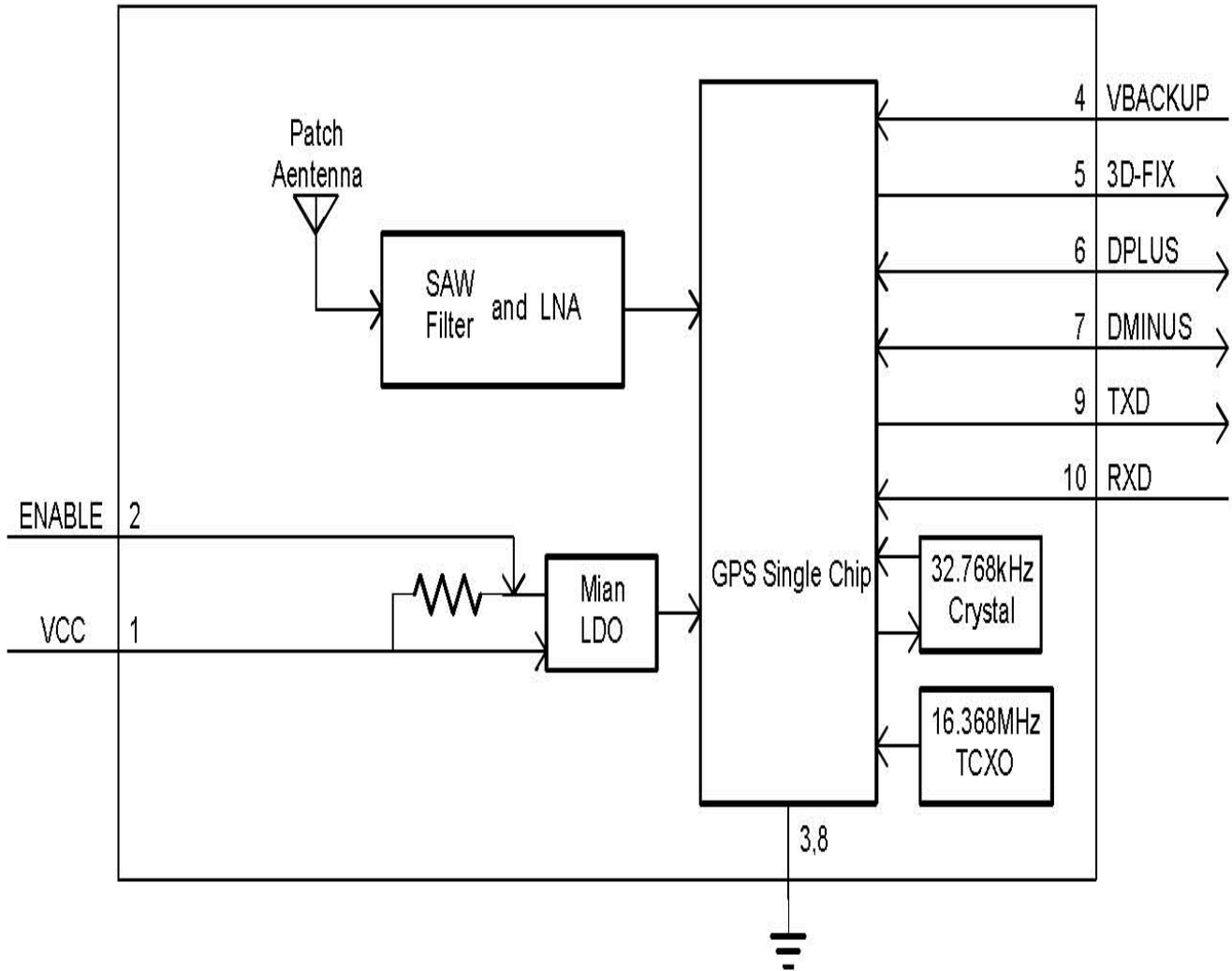

The document is the exclusive property of GlobalTop Tech Inc. and should not be distributed, reproduced, or any other format without prior permission of GlobalTop Tech Inc. Specifications subject to change without prior notice

GlobalTop Tech Inc.

16 Nan-ke 9th Rd Science-based Industrial Park, Tainan 741, Taiwan, R.O.C.
 Tel:+886-6-6007799 Fax:+886-6-5053381 <http://www.gtop-tech.com/> email: sales@gtop-tech.com
 Copyright© 2007 GlobalTop Tech Inc. All right reserved.



FGPMMOPA6 Datasheet

Rev.A02

Mechanical

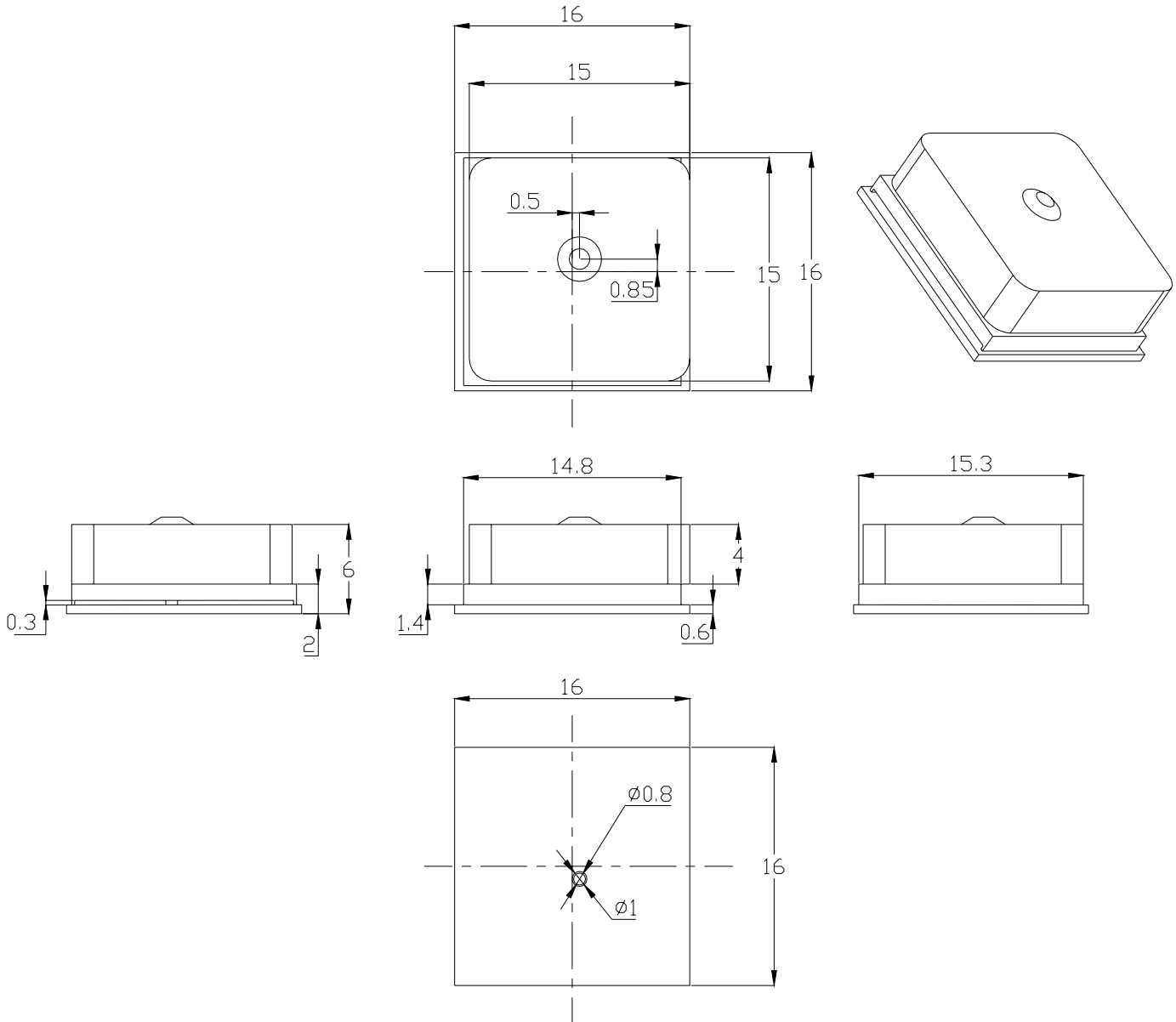

Unit: mm

The document is the exclusive property of GlobalTop Tech Inc. and should not be distributed, reproduced, or any other format without prior permission of GlobalTop Tech Inc. Specifications subject to change without prior notice

GlobalTop Tech Inc.

16 Nan-ke 9th Rd Science-based Industrial Park, Tainan 741, Taiwan, R.O.C.

Tel: +886-6-6007799 Fax: +886-6-5053381 <http://www.gtop-tech.com/> email: sales@gtop-tech.com

Copyright© 2007 GlobalTop Tech Inc. All right reserved.

Recommend PCB Layout Pad

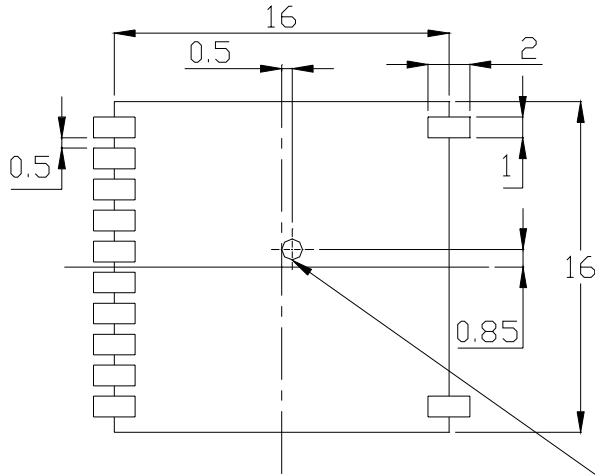

Footprint Top View

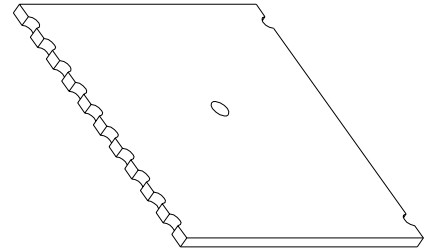

No traces and vias are allowed to pass the area.

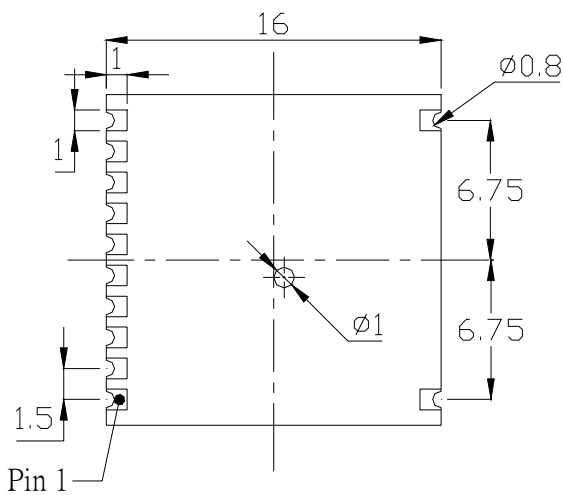
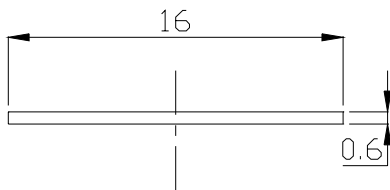

PCB Bottom View

Unit: mm

The document is the exclusive property of GlobalTop Tech Inc. and should not be distributed, reproduced, or any other format without prior permission of GlobalTop Tech Inc. Specifications subject to change without prior notice

GlobalTop Tech Inc.

16 Nan-ke 9th Rd Science-based Industrial Park, Tainan 741, Taiwan, R.O.C.

Tel: +886-6-6007799 Fax: +886-6-5053381 <http://www.gtop-tech.com/> email: sales@gtop-tech.com

Copyright© 2007 GlobalTop Tech Inc. All right reserved.

Pin Configuration

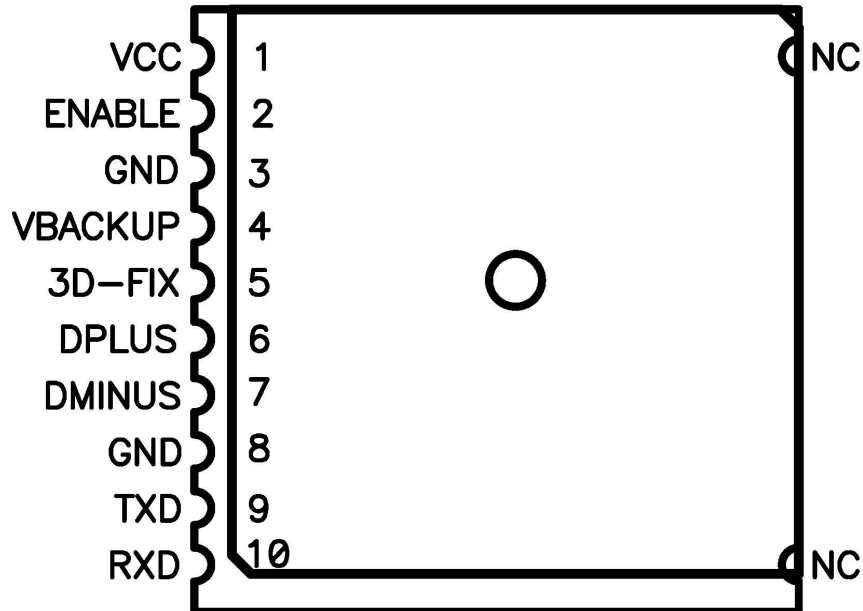

Top View

Pin Definition

Pin	Name	I/O	Description
1	VCC	PI	Main DC power input
2	ENABLE	I	High active, or keep floating for normal working
3	GND	P	Ground
4	VBACKUP	PI	Backup power input
5	3D-FIX	O	3D-fix indicator
6	DPLUS	I/O	USB port D+
7	DMINUS	I/O	USB port D-
8	GND	P	Ground
9	TXD	O	Serial data output of NMEA
10	RXD	I	Serial data input for firmware update

The document is the exclusive property of GlobalTop Tech Inc. and should not be distributed, reproduced, or any other format without prior permission of GlobalTop Tech Inc. Specifications subject to change without prior notice

GlobalTop Tech Inc.

16 Nan-ke 9th Rd Science-based Industrial Park, Tainan 741, Taiwan, R.O.C.
 Tel: +886-6-6007799 Fax: +886-6-5053381 <http://www.gtop-tech.com/> email: sales@gtop-tech.com
 Copyright© 2007 GlobalTop Tech Inc. All right reserved.



FGPMMOPA6 Datasheet

Rev.A02

Description of I/O Pin

VCC (Pin1)

The main DC power supply of the module. The voltage should be kept between from 3.2V to 5.0V. (Typical : 3.3V)

ENABLE (Pin2)

Keep open or pull high to Power ON. Pull low to shutdown the module.

Enable (High): $1.8V \leq V_{enable} \leq VCC$

Disable (Low): $0V \leq V_{enable} \leq 0.25V$

GND (Pin3)

Ground.

VBACKUP (Pin4)

This is the power for GPS chipset to keep RTC running when main power is removed. The voltage should be kept between 2.0V~4.3V . (Typical : 3.0V)

3D-FIX (Pin5)

The 3D-FIX was assigned as fix flag output. If not used, keep floating.

■ Before 2D Fix

The should continuously output one-second high-level with one-second low-level signal.

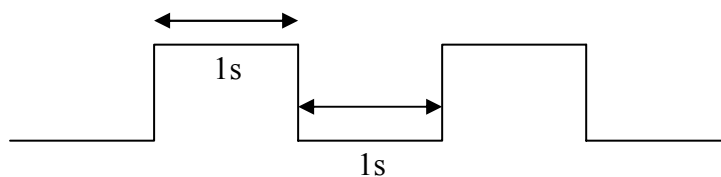

■ After 2D or 3D Fix

The should continuously output low-level signal.

Low _____

The document is the exclusive property of GlobalTop Tech Inc. and should not be distributed, reproduced, or any other format without prior permission of GlobalTop Tech Inc. Specifications subject to change without prior notice

GlobalTop Tech Inc.

16 Nan-ke 9th Rd Science-based Industrial Park, Tainan 741, Taiwan, R.O.C.

Tel:+886-6-6007799 Fax:+886-6-5053381 <http://www.gtop-tech.com/> email: sales@gtop-tech.com

Copyright© 2007 GlobalTop Tech Inc. All right reserved.



FGPMMOPA6 Datasheet

Rev.A02

DPLUS (Pin6)

USB Port DPLUS Signal

DMINUS (Pin7)

USB Port DMINUS Signal

GND (Pin8)

Ground.

TXD (Pin9)

This is the UART transmitter of the module. It outputs the GPS information for application.

RXD (Pin10)

This is the UART receiver of the module. It is used to receive software commands and firmware update.

The document is the exclusive property of GlobalTop Tech Inc. and should not be distributed, reproduced, or any other format without prior permission of GlobalTop Tech Inc. Specifications subject to change without prior notice

GlobalTop Tech Inc.

16 Nan-ke 9th Rd Science-based Industrial Park, Tainan 741, Taiwan, R.O.C.

Tel:+886-6-6007799 Fax:+886-6-5053381 <http://www.gtop-tech.com/> email: sales@gtop-tech.com

Copyright© 2007 GlobalTop Tech Inc. All right reserved.

Reference Design

USB Interface

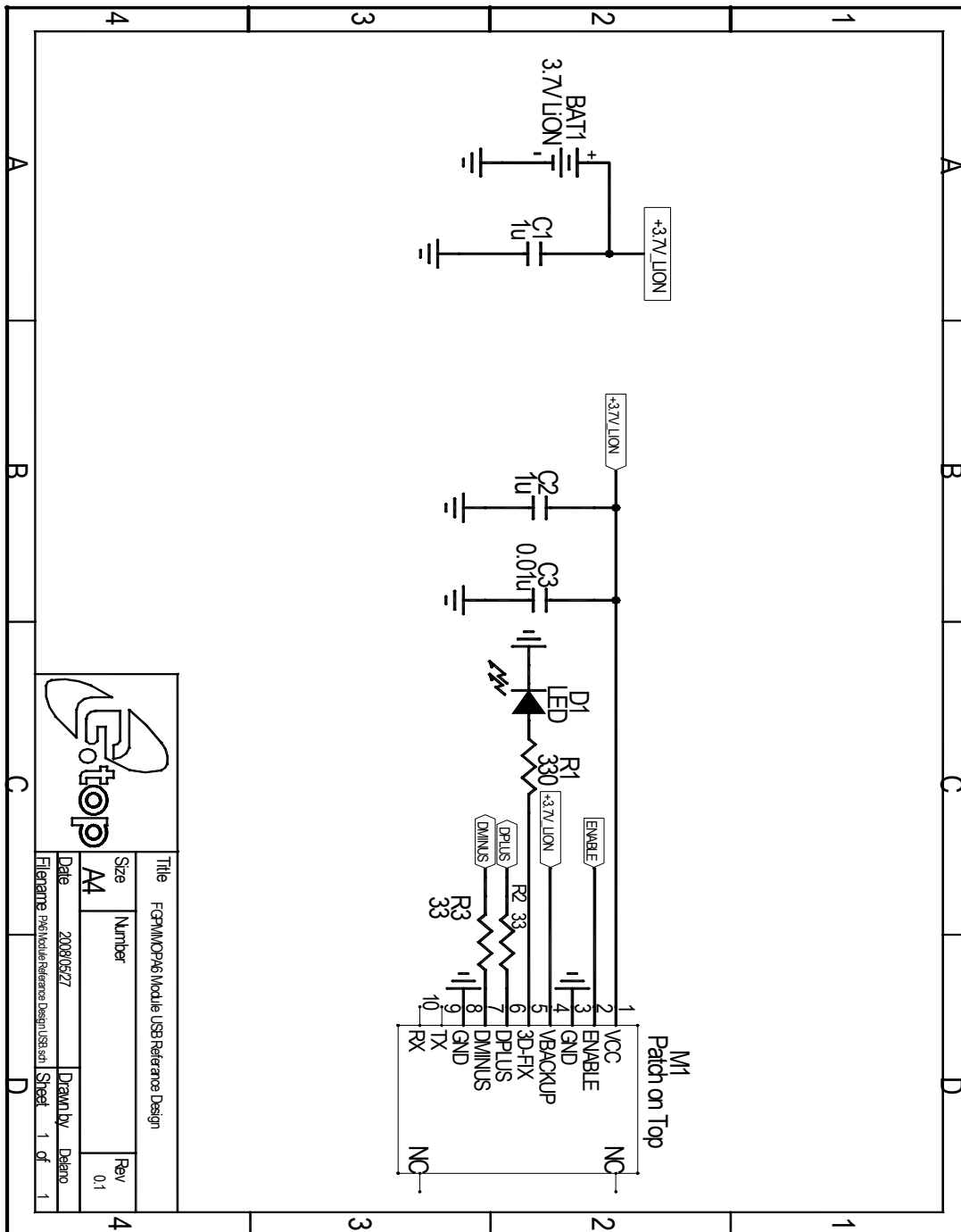

The document is the exclusive property of GlobalTop Tech Inc. and should not be distributed, reproduced, or any other format without prior permission of GlobalTop Tech Inc. Specifications subject to change without prior notice

GlobalTop Tech Inc.

16 Nan-ke 9th Rd Science-based Industrial Park, Tainan 741, Taiwan, R.O.C.

Tel: +886-6-6007799 Fax: +886-6-5053381 <http://www.gtop-tech.com/> email: sales@gtop-tech.com

Copyright© 2007 GlobalTop Tech Inc. All right reserved.

UART Interface

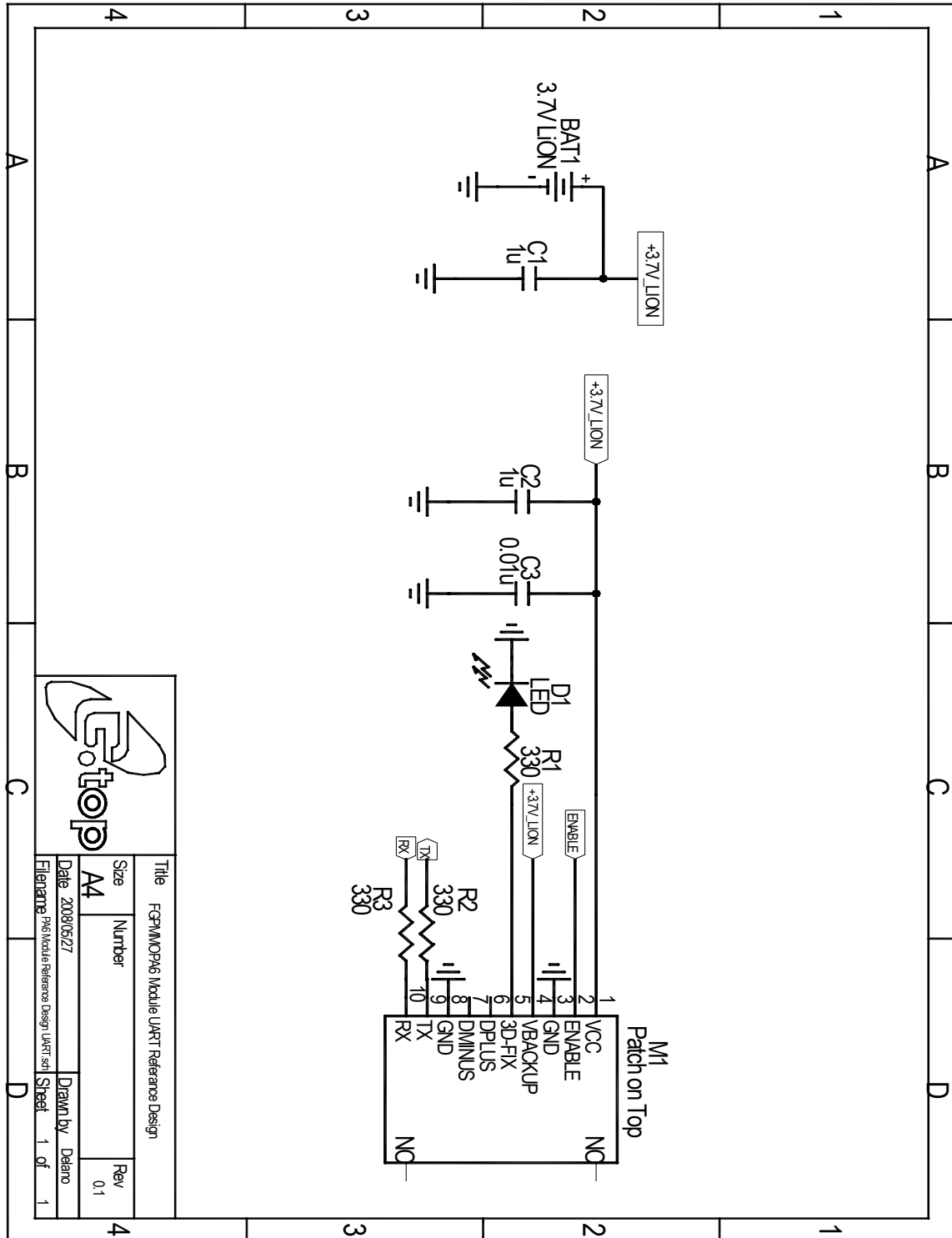

The document is the exclusive property of GlobalTop Tech Inc. and should not be distributed, reproduced, or any other format without prior permission of GlobalTop Tech Inc. Specifications subject to change without prior notice

GlobalTop Tech Inc.

16 Nan-ke 9th Rd Science-based Industrial Park, Tainan 741, Taiwan, R.O.C.

Tel: +886-6-6007799 Fax: +886-6-5053381 <http://www.gtop-tech.com/> email: sales@gtop-tech.com

Copyright© 2007 GlobalTop Tech Inc. All right reserved.



FGPMMOPA6 Datasheet

Rev.A02

Specifications

General	
Chipset	MTK MT3329
Frequency	L1, 1575.42MHz
C/A Code	1.023 MHz
Channels	66 channels
SBAS	WAAS, EGNOS,MSAS Supported
Datum	WGS84(Default), Tokyo-M, Tokyo-A, User Define
CPU	ARM7EJ-S
Dimensions	
Length/Width/Height	16*16*6 mm
Weight	6g
Performance Characteristics	
Position Accuracy	Without aid : 3.0m 2D-RMS
	< 3m CEP (50%) without SA (horizontal)
	DGPS (RTCM, SBAS (WAAS, EGNOS, MSAS)) : 2.5m
Velocity Accuracy	Without aid : 0.1 m/s
	DGPS (RTCM, SBAS (WAAS, EGNOS, MSAS)) : 0.05m/s
Acceleration Accuracy	Without aid : 0.1 m/s ²
	DGPS (RTCM, SBAS (WAAS, EGNOS, MSAS)) : 0.05m/s ²
Timing Accuracy	100 ns RMS
Sensitivity	Acquisition : -148dBm (Cold Start)
	Reacquisition : -157dBm
	Tracking : -163dBm
Maximum Update Rate	Up to 5Hz(Default: 1Hz)
Acquisition (Open sky, stationary)	
Reacquisition Time	Less than 1 second
Hot start	1.0s (Typical)
Warm start	34s (Typical)

The document is the exclusive property of GlobalTop Tech Inc. and should not be distributed, reproduced, or any other format without prior permission of GlobalTop Tech Inc. Specifications subject to change without prior notice

GlobalTop Tech Inc.

16 Nan-ke 9th Rd Science-based Industrial Park, Tainan 741, Taiwan, R.O.C.
Tel:+886-6-6007799 Fax:+886-6-5053381 <http://www.gtop-tech.com/> email: sales@gtop-tech.com
Copyright© 2007 GlobalTop Tech Inc. All right reserved.



FGPMMOPA6 Datasheet

Rev.A02

Cold start	35s (Typical)
Dynamic	
Altitude	Maximum 18,000m
Velocity	Maximum 515m/s
Acceleration	Maximum 4G
Power	
Input Voltage	DC 3.3V Typical
Power Consumption @ 3.3V	Acquisition : 48mA Typical
	Tracking : 37mA Typical
I/O	
Signal Output	8 data bits, no parity, 1 stop bit
Available Baud Rates	4800/9600/38400/57600/115200 bps(Default : 9600)
Protocols	NMEA 0183 v3.01 (Default : GGA,GSA,GSV,RMC,VTG) RTCM MTK NMEA Command Network Assistance Messages
Data output Interface	
USB Interface	Logo certified USB 2.0 full-speed compatible
Environment	
Operating Temperature	-40 °C to 85 °C
Storage Temperature	-50 °C to 90 °C
Operating Humidity	5% to 95% (no condensing)

DC Characteristics

Parameter	Condition	Min.	Typ.	Max.	Unit
Operation supply Voltage	VCC	3.2	3.3	5.0	V
Operation supply Ripple Voltage	—	—	—	50	mVpp
Backup Battery Voltage	—	2.0	3.0	4.3	V
RXA TTL H Level	VCC=3.3V	2.1	—	VCC	V
RXA TTL L Level	VCC=3.3V	0	—	0.9	V
TXA TTL H Level	VCC=3.3V	2.1	—	2.8	V
TXA TTL L Level	VCC=3.3V	0	—	0.8	V

The document is the exclusive property of GlobalTop Tech Inc. and should not be distributed, reproduced, or any other format without prior permission of GlobalTop Tech Inc. Specifications subject to change without prior notice

GlobalTop Tech Inc.

16 Nan-ke 9th Rd Science-based Industrial Park, Tainan 741, Taiwan, R.O.C.
Tel:+886-6-6007799 Fax:+886-6-5053381 <http://www.gtop-tech.com/> email: sales@gtop-tech.com
Copyright© 2007 GlobalTop Tech Inc. All right reserved.



FGPMMOPA6 Datasheet

Rev.A02

NMEA Output Sentence

Table-1 lists each of the NMEA output sentences specifically developed and defined by MTK for use within MTK products

NMEA Output Sentence		Table-1
Option	Description	
GGA	Time, position and fix type data.	
GSA	GPS receiver operating mode, active satellites used in the position solution, and DOP values.	
GSV	The number of GPS satellites in view satellite ID numbers, elevation, azimuth, and SNR values.	
RMC	Time, date, position, course and speed data. Recommended Minimum Navigation Information.	
VTG	Course and speed information relative to the ground.	

The document is the exclusive property of GlobalTop Tech Inc. and should not be distributed, reproduced, or any other format without prior permission of GlobalTop Tech Inc. Specifications subject to change without prior notice

GlobalTop Tech Inc.

16 Nan-ke 9th Rd Science-based Industrial Park, Tainan 741, Taiwan, R.O.C.
Tel:+886-6-6007799 Fax:+886-6-5053381 <http://www.gtop-tech.com/> email: sales@gtop-tech.com
Copyright© 2007 GlobalTop Tech Inc. All right reserved.



FGPMMOPA6 Datasheet

Rev.A02

GGA—Global Positioning System Fixed Data. Time, Position and fix related data for a GPS receiver

Table-2 contains the values for the following example :

\$GPGGA,064951.000,2307.1256,N,12016.4438,E,1,8,0.95,39.9,M,17.8,M,,*65

GGA Data Format			Table-2
Name	Example	Units	Description
Message ID	\$GPGGA		GGA protocol header
UTC Time	064951.000		hhmmss.sss
Latitude	2307.1256		ddmm.mmmm
N/S Indicator	N		N=north or S=south
Longitude	12016.4438		dddmm.mmmm
E/W Indicator	E		E=east or W=west
Position Fix Indicator	1		See Table-3
Satellites Used	8		Range 0 to 14
HDOP	0.95		Horizontal Dilution of Precision
MSL Altitude	39.9	meters	Antenna Altitude above/below mean-sae-level
Units	M	meters	Units of antenna altitude
Geoidal Separation	17.8	meters	
Units	M	meters	Units of geoidal separation
Age of Diff. Corr.		second	Null fields when DGPS is not used
Checksum	*65		
<CR> <LF>			End of message termination

Position Fix Indicator		Table-3
Value	Description	
0	Fix not available	
1	GPS fix	
2	Differential GPS fix	

The document is the exclusive property of GlobalTop Tech Inc. and should not be distributed, reproduced, or any other format without prior permission of GlobalTop Tech Inc. Specifications subject to change without prior notice

GlobalTop Tech Inc.

16 Nan-ke 9th Rd Science-based Industrial Park, Tainan 741, Taiwan, R.O.C.
 Tel:+886-6-6007799 Fax:+886-6-5053381 <http://www.gtop-tech.com/> email: sales@gtop-tech.com
 Copyright© 2007 GlobalTop Tech Inc. All right reserved.



FGPMMOPA6 Datasheet

Rev.A02

GSA—GNSS DOP and Active Satellites

Table-4 contains the values for the following example :

\$GPGSA,A,3,29,21,26,15,18,09,06,10,,,,,2.32,0.95,2.11*00

GSA Data Format			Table-4
Name	Example	Units	Description
Message ID	\$GPGSA		GSA protocol header
Mode 1	A		See Table-5
Mode 2	3		See Table-6
Satellite Used	29		SV on Channel 1
Satellite Used	21		SV on Channel 2
....
Satellite Used			SV on Channel 12
PDOP	2.32		Position Dilution of Precision
HDOP	0.95		Horizontal Dilution of Precision
VDOP	2.11		Vertical Dilution of Precision
Checksum	*00		
<CR> <LF>			End of message termination

Mode 1		Table-5
Value	Description	
M	Manual—forced to operate in 2D or 3D mode	
A	2D Automatic—allowed to automatically switch 2D/3D	

Mode 2		Table-6
Value	Description	
1	Fix not available	
2	2D (< 4 SVs used)	
3	3D (\geq 4 SVs used)	

The document is the exclusive property of GlobalTop Tech Inc. and should not be distributed, reproduced, or any other format without prior permission of GlobalTop Tech Inc. Specifications subject to change without prior notice

GlobalTop Tech Inc.

16 Nan-ke 9th Rd Science-based Industrial Park, Tainan 741, Taiwan, R.O.C.
 Tel:+886-6-6007799 Fax:+886-6-5053381 <http://www.gtop-tech.com/> email: sales@gtop-tech.com
 Copyright© 2007 GlobalTop Tech Inc. All right reserved.



FGPMMOPA6 Datasheet

Rev.A02

GSV—GNSS Satellites in View

Table-7 contains the values for the following example :

\$GPGSV,3,1,09,29,36,029,42,21,46,314,43,26,44,020,43,15,21,321,39*7D

\$GPGSV,3,2,09,18,26,314,40,09,57,170,44,06,20,229,37,10,26,084,37*77

\$GPGSV,3,3,09,07,,,26*73

GSV Data Format			Table-7
Name	Example	Units	Description
Message ID	\$GPGSV		GSV protocol header
Number of Messages	3		Range 1 to 3 <i>(Depending on the number of satellites tracked, multiple messages of GSV data may be required.)</i>
Message Number1	1		Range 1 to 3
Satellites in View	09		
Satellite ID	29		Channel 1 (Range 1 to 32)
Elevation	36	degrees	Channel 1 (Maximum 90)
Azimuth	029	degrees	Channel 1 (True, Range 0 to 359)
SNR (C/No)	42	dBHz	Range 0 to 99, (null when not tracking)
....
Satellite ID	15		Channel 4 (Range 1 to 32)
Elevation	21	degrees	Channel 4 (Maximum 90)
Azimuth	321	degrees	Channel 4 (True, Range 0 to 359)
SNR (C/No)	39	dBHz	Range 0 to 99, (null when not tracking)
Checksum	*7D		
<CR> <LF>			End of message termination

The document is the exclusive property of GlobalTop Tech Inc. and should not be distributed, reproduced, or any other format without prior permission of GlobalTop Tech Inc. Specifications subject to change without prior notice

GlobalTop Tech Inc.

16 Nan-ke 9th Rd Science-based Industrial Park, Tainan 741, Taiwan, R.O.C.
 Tel:+886-6-6007799 Fax:+886-6-5053381 <http://www.gtop-tech.com/> email: sales@gtop-tech.com
 Copyright© 2007 GlobalTop Tech Inc. All right reserved.



FGPMMOPA6 Datasheet

Rev.A02

RMC—Recommended Minimum Navigation Information

Table-8 contains the values for the following example :

\$GPRMC,064951.000,A,2307.1256,N,12016.4438,E,0.03,165.48,260406,,A*55

RMC Data Format			Table-8
Name	Example	Units	Description
Message ID	\$GPRMC		RMC protocol header
UTC Time	064951.000		hhmmss.sss
Status	A		A=data valid or V=data not valid
Latitude	2307.1256		ddmm.mmmm
N/S Indicator	N		N=north or S=south
Longitude	12016.4438		dddmm.mmmm
E/W Indicator	E		E=east or W=west
Speed Over Ground	0.03	knots	
Course Over Ground	165.48	degrees	True
Date	260406		ddmmyy
Magnetic Variation		degrees	E=east or W=west <i>(MTK does support magnetic declination)</i>
Mode	A		A= Autonomous mode D= Differential mode E= Estimated mode
Checksum	*65		
<CR> <LF>			End of message termination

The document is the exclusive property of GlobalTop Tech Inc. and should not be distributed, reproduced, or any other format without prior permission of GlobalTop Tech Inc. Specifications subject to change without prior notice

GlobalTop Tech Inc.

16 Nan-ke 9th Rd Science-based Industrial Park, Tainan 741, Taiwan, R.O.C.
 Tel: +886-6-6007799 Fax: +886-6-5053381 <http://www.gtop-tech.com/> email: sales@gtop-tech.com
 Copyright© 2007 GlobalTop Tech Inc. All right reserved.



FGPMMOPA6 Datasheet

Rev.A02

VTG—Course and speed information relative to the ground.

Table-9 contains the values for the following example :

\$GPVTG,165.48,T,,M,0.03,N,0.06,K,A*37

VTG Data Format			Table-9
Name	Example	Units	Description
Message ID	\$GPVTG		VTG protocol header
Course	165.48	degrees	Measured heading
Reference	T		True
Course		degrees	Measured heading
Reference	M		Magnetic <i>(MTK does not support magnetic declination.)</i>
Speed	0.03	knots	Measured horizontal speed
Units	N		Knots
Speed	0.06	km/hr	Measured horizontal speed
Units	K		Kilometers per hour
Mode	A		A= Autonomous mode D= Differential mode E= Estimated mode
Checksum	*06		
<CR> <LF>			End of message termination

MTK NMEA Command Protocol

Packet Type :

103 PMTK_CMD_COLD_START

Packet Meaning :

Cold Start : Don't use Time, Position, Almanacs and Ephemeris data at re-start.

Example :

\$PMTK103*30<CR><LF>

The document is the exclusive property of GlobalTop Tech Inc. and should not be distributed, reproduced, or any other format without prior permission of GlobalTop Tech Inc. Specifications subject to change without prior notice

GlobalTop Tech Inc.

16 Nan-ke 9th Rd Science-based Industrial Park, Tainan 741, Taiwan, R.O.C.

Tel:+886-6-6007799 Fax:+886-6-5053381 <http://www.gtop-tech.com/> email: sales@gtop-tech.com

Copyright© 2007 GlobalTop Tech Inc. All right reserved.



FGPMMOPA6 Datasheet

Rev.A02

Solder-Reflow Condition

Reflow Condition (Follow JEDEC-020C)

Average ramp-up rate (217°C to peak) : 3°C/sec. max.

Preheat : 150 ~ 200°C 、 60~180 seconds

Temperature maintained above 217°C : 60 ~ 150 seconds

Time within 5°C of actual peak temperature : 20 ~ 40 seconds

Peak temperature : 250+0/-5°C

Ramp-down rate : 6°C/sec. max.

Time 25°C to peak temperature : 8 minutes max.

Cycle interval : 5 minus

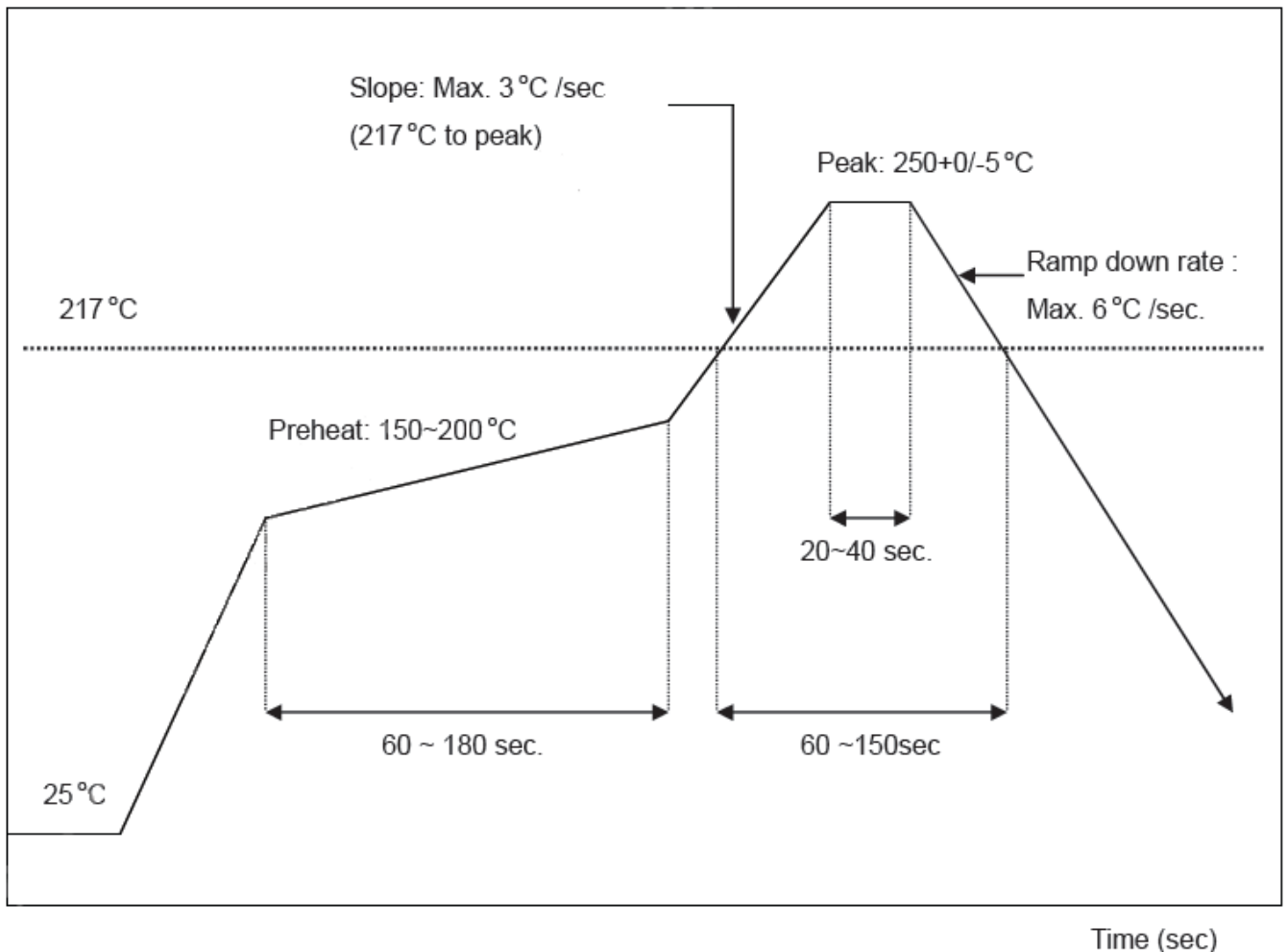

The document is the exclusive property of GlobalTop Tech Inc. and should not be distributed, reproduced, or any other format without prior permission of GlobalTop Tech Inc. Specifications subject to change without prior notice

GlobalTop Tech Inc.

16 Nan-ke 9th Rd Science-based Industrial Park, Tainan 741, Taiwan, R.O.C.
Tel:+886-6-6007799 Fax:+886-6-5053381 <http://www.gtop-tech.com/> email: sales@gtop-tech.com
Copyright© 2007 GlobalTop Tech Inc. All right reserved.