



MMsam7s

Minimodule with
ARM microcontroller

User Guide

REV 0.8

Tropo®
Many ideas one solution

Contents

1 INTRODUCTION	3
FEATURES	3
2 THE MODULE	4
BLOCK DIAGRAM	4
TERMINALS LAYOUT	5
AT91SAM7S MICROCONTROLLER	6
DATAFLASH MEMORY	6
VOLTAGE REGULATOR	6
USB D+ PULL-UP CIRCUIT	7
JTAG CONNECTOR	7
3 EVALUATION BOARD	8
4 SPECIFICATIONS	9
5 TECHNICAL ASSISTANCE	9
6 GUARANTEE	9
7 ASSEMBLY DRAWINGS	10
8 DIMENSIONS	11
9 SCHEMATIC	11

Introduction

MMsam7s is universal minimodule for the AT91SAM7S microcontrollers from Atmel. This microcontroller is available in the TQFP64 case which is difficult to apply to prototype and amateur circuits due to the compactness of pins. We have undertaken an attempt at placing it on a board of 36x36mm with a layout of leads which matches the commonly available prototype circuit boards. In addition, we have included 3.3V voltage regulator, a serial DataFlash memory with a capacity of up to 4MB, and crystal resonator. All ports and signals of the microcontroller are lead out by means of two-row pin connectors with 0.1" pitch. This minimodule is not only an adapter but a complete main board for AT91SAM7S. It needs only a connection to the supply voltage and to the JTAG connector and we can start loading 256kBytes of Flash memory of the microcontroller. Through integration of the peripherals with the microcontrollers on one board, the application of this module can lead to a shorter design period and facilitate the construction of systems based on ARM microcontrollers, by eliminating the need to design the printed board. The module is supplied with example software.

The **MMsam7s** minimodule can be also used in didactic laboratories of informatics colleges and universities, and can be also used to build circuits realizing thesis projects.

Features

MMsam7s minimodule:

- Complete, ready to use microprocessor system
- Fast ARM microcontroller AT91SAM7S with up to 55 MIPS throughput
- Serial DataFlash memory 32Mb (4MB)
- Built-in crystal resonator 18.432MHz
- Built-in voltage regulator 3.3V 400mA
- Module supply voltage: 3.3V or 3.8 - 16V
- 2 x 26 terminals with 0.1" (2.54mm) pitch fitting every prototype board
- Small dimensions: 36mm x 36mm (1400x1400mils)
- Available evaluation board and sample applications

2 The module

Block diagram

A block diagram of MMsa7s minimodule is shown on the image below:

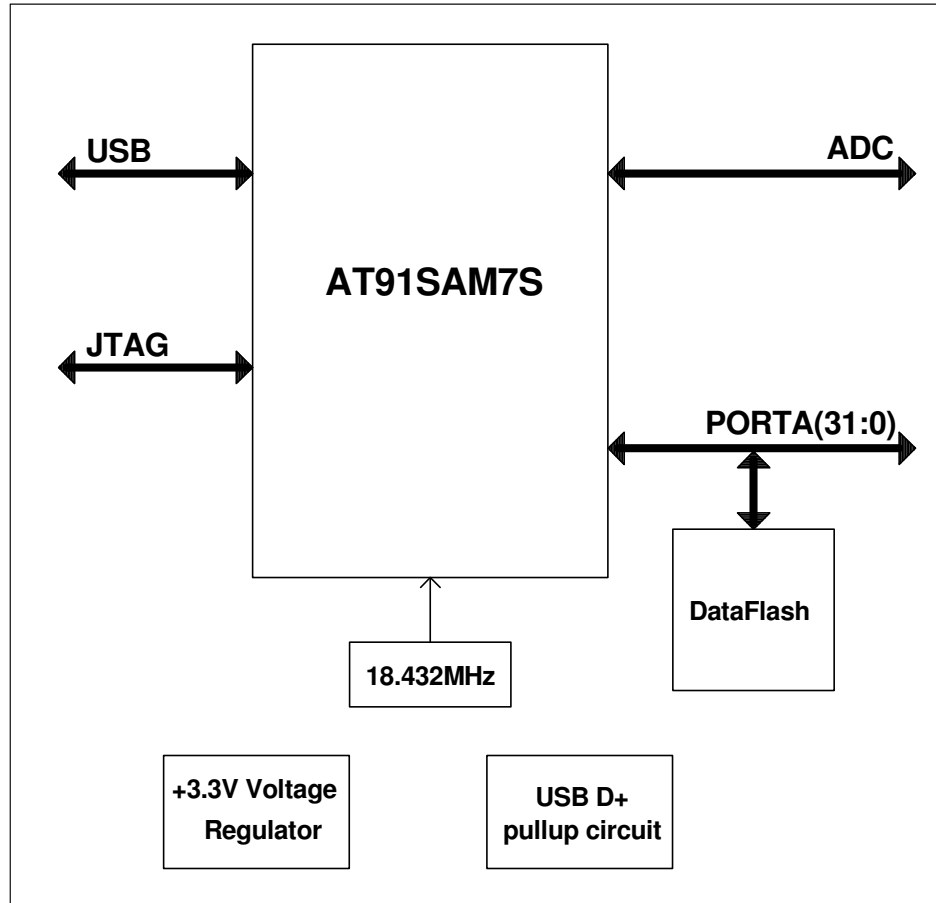
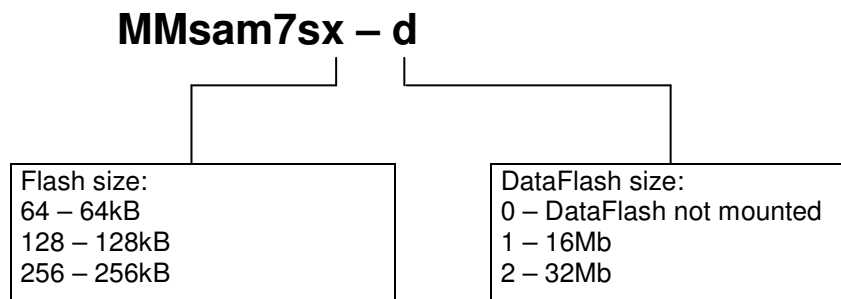

Figure 1 Block diagram of MMsam7s minimodule.

Minimodule can be ordered in different configurations with use of selector:



For example: MMAT91SAM64-0 – minimodule with AT91SAM7S256 (256kB Flash) microcontroller, with 32Mb DataFlash memoyr.

Terminals layout

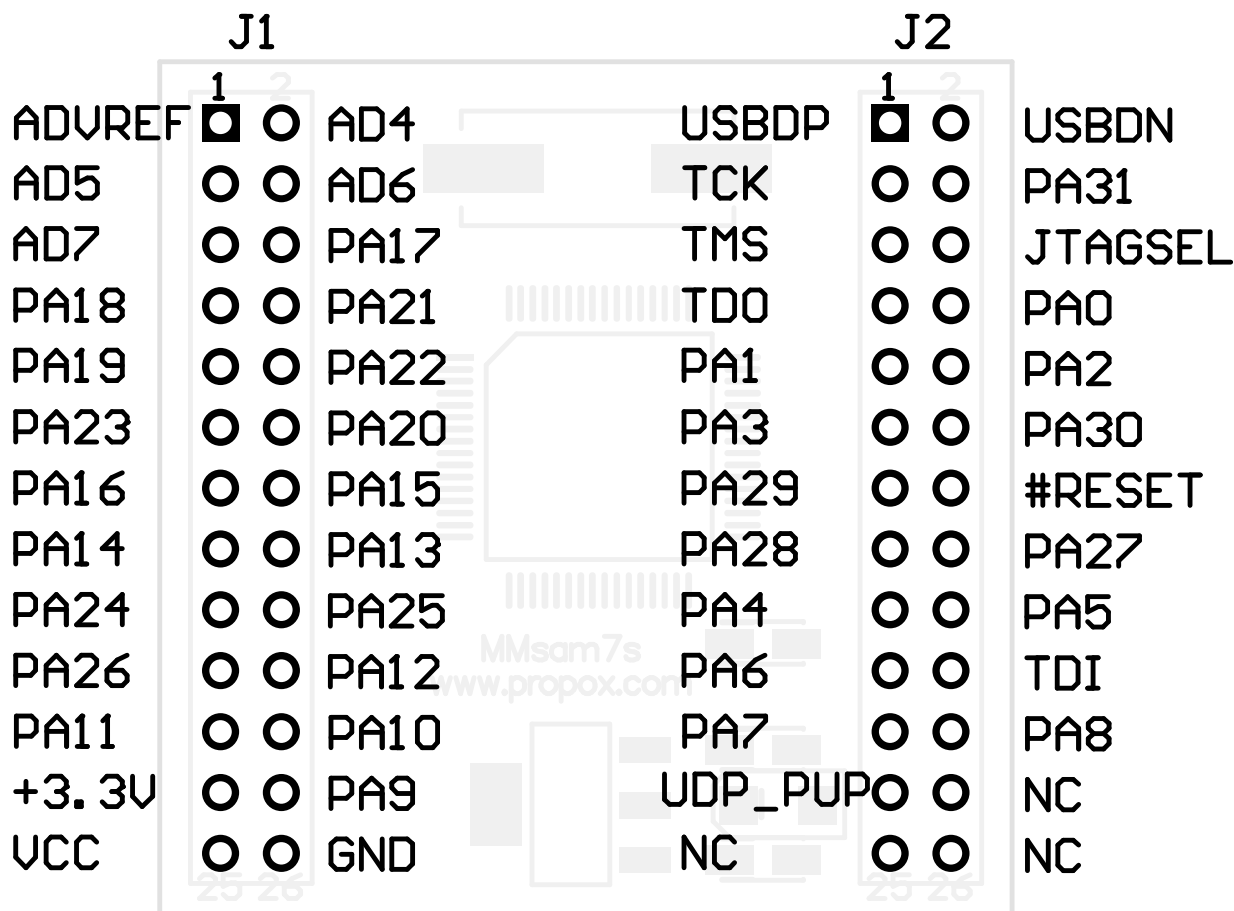

Figure 2 Terminals layout – top view.

Name	J1		Name	J2		Name
ADVREF	1	2	AD4	1	2	USB DP
AD5	3	4	AD6	3	4	PA31
AD7	5	6	PA17	5	6	JTAGSEL
PA18/PGMD6/AD1	7	8	PA21/PGMD9	7	8	PA0/PMEN0
PA19/PGMD7/AD2	9	10	PA22/PGMD10	9	10	PA2
PA23/PGMD11	11	12	PA20/PGMD8/AD3	11	12	PA30
PA16/PGMD4	13	14	PA15/PGMD3	13	14	#RESET
PA14/PGMD2	15	16	PA13/PGMD1	15	16	PA27/PGMD15
PA24/PGMD12	17	18	PA25/PGMD13	17	18	PA5/PGMRDY
PA26/PGMD14	19	20	PA12/PGMD0	19	20	TDI
PA11/PGMM3	21	22	PA10/PGMM2	21	22	PA8/PHMM0
+3.3V	23	24	PA9/PGMM1	23	24	NC
VCC	25	26	GND	25	26	NC

(1) – terminals used for connecting DataFlash memory on the module.

Detailed description of ports can be found in microcontroller datasheets.

AT91SAM7S microcontroller

- 32-bit ARM7TDMI core
- From 32 to 256kB in system programmable flash memory
- From 8 to 64kB RAM memory
- 3 timers with input capture, output compare and PWM functions
- Periodic Interval timer
- Real-time Timer
- Four-channel 16-bit PWM controller
- 2 USART interfaces
- Debug Unit
- One Synchronous Serial Controller
- I2C interface
- SPI interface
- USB interface
- 8-channel 10-bit A/D converter
- 5V tolerant I/O ports
- Advanced Interrupt Controller
- Windowed Watchdog
- Power savings modes
- RTC clock
- Single power supply 3.3V (internal 1.8V regulator)
- JTAG interface

DataFlash memory

The minimodule can be equipped with serial DataFlash memory AT45DB161B or AT45DB321C (16Mb or 32 Mb capacities). The memory is connected to a fast SPI bus with up to 55MB/s transmission speed.

Memory chip is activated after applying a low logic level to #CS input. The #CS input of memory is connected to port PA31 of the microcontroller. The SPI bus occupies three terminals of the microprocessor: PA12, PA13 and PA14. It should be kept in mind that if DataFlash memory is installed, the just outlined port terminals cannot be used externally to the module. Of course the SPI bus can be used for communication with external peripherals, under the condition that they will have circuit selection inputs (CS). The diagram below shows the connection of DataFlash memory inside the module.

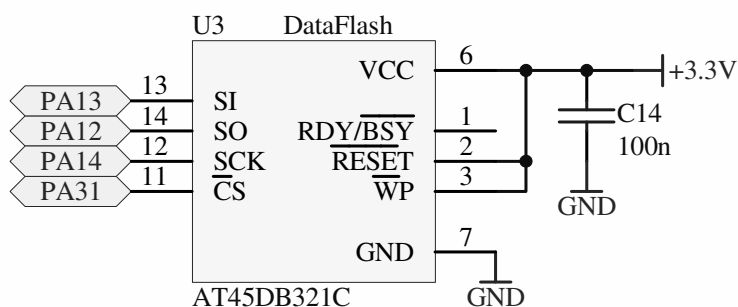

Figure 3 Connection of DataFlash memory inside the module.

A detailed description of DataFlash circuits is on the Atmel Company page: www.atmel.com.

Voltage regulator

Minimodule has built-in 3.3V voltage regulator. Thanks to it can be powered with 3.3V voltage supplied to J1 23 pin (+3.3V) or with voltage between 3.8 – 16V, supplied to J1 25 pin (VCC). When power is supplied to VCC pin, then 3.3V voltage is produced on the module by U2 regulator. In this case 3.3V voltage can be also used outside the module, if current draw will not exceed 300mA.

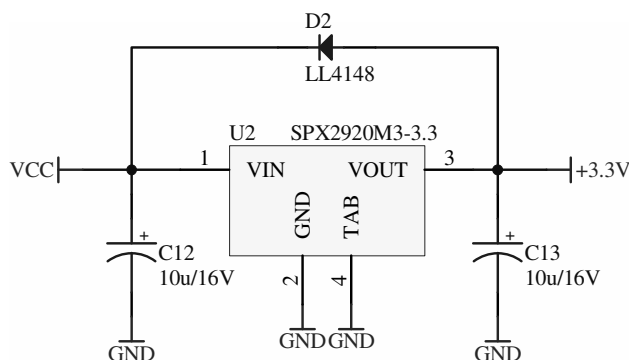

Figure 4 3.3V voltage regulator.

USB D+ pull-up circuit

USB host recognize presence of device on the bus by sensing pull-up on D+ line. MMsam7s has built-in pull-up circuit, shown on drawing below.

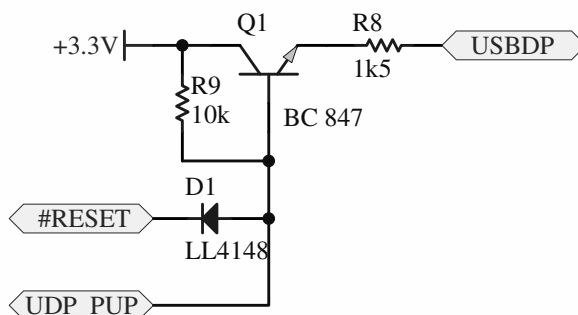

Figure 5 Implementation of D+ pull-up circuit.

Pull-up is by default turned on by R13 resistor. Active reset signal or low level on UDP_PUP line turns off pull-up, what is interpreted by USB host as disconnection of USB device.

JTAG connector

Programming/debugging of module can be done through JTAG interface.

JTAG is a four-lead interface permitting the takeover of control over the processor's core. The possibilities offered by this interface are, among others: step operation, full-speed operation, hardware and software breakpoints, inspection and modification of contents of registers and data memories. The method of connecting the JTAG connector to the minimodule is shown in the drawing:

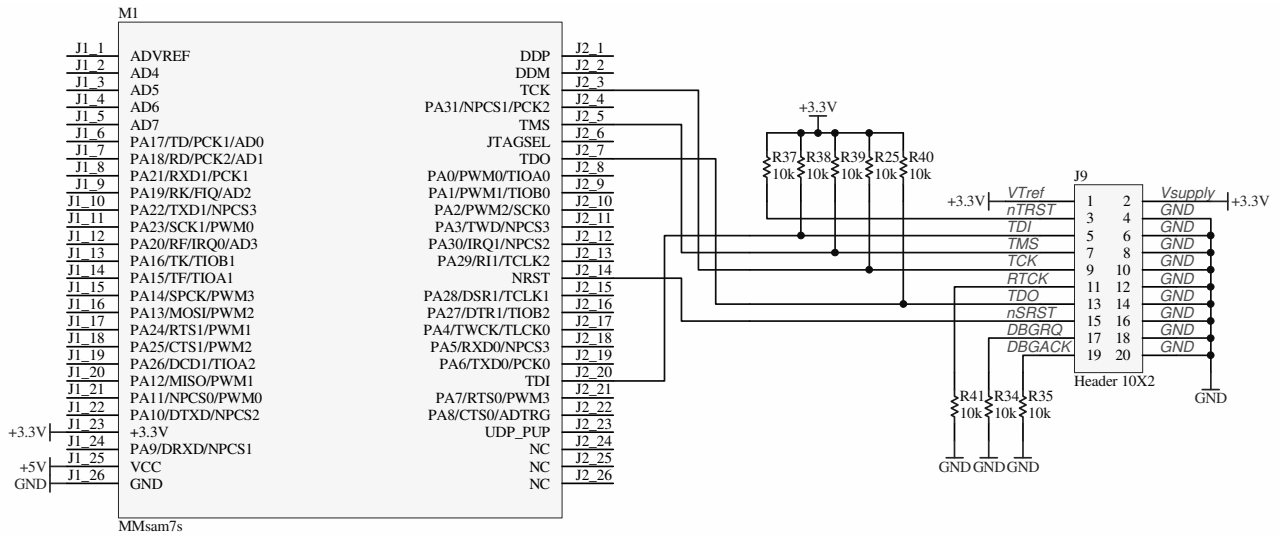

Figure 6 Connection of JTAG interface to MMsam7s.

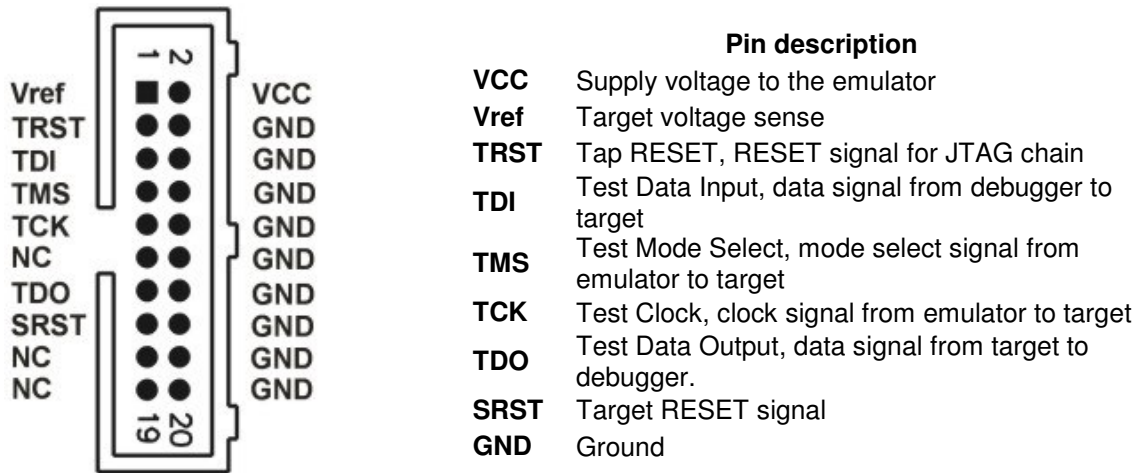

Figure 7 JTAG connector.

JTAG programmer/debugger may be found on page:
 - ARMCable I: http://www.propox.com/products/t_122.html

3 Evaluation Board

In order to facilitate the design of equipment using the minimodule, an evaluation board has been prepared. It includes the following elements:

- Socket for the MMsam7s module
- Connector with all terminals of the MMsam7s module
- Connectors of all peripherals accessible on board
- Power supply
- Power switch
- USB connector
- Two RS232 ports
- 1-Wire connector
- JTAG connector for in system programming and debugging
- connector for 2x16 LCD display
- 8 LED diodes
- 4 push-buttons
- 2 potentiometers
- Buzzer
- Prototype design area



4 Specifications

Microcontroller	AT91SAM7S
Program memory	Up to 256kB
Data memory	Up to 64kB
DataFlash memory	Up to 4MB
No. of digital I/O	Up to 32
No. of analog inputs	Up to 8
Power	3.3V or 3.8 – 16V
Dimensions	36x36mm
Weight	About 80g
Operating temperature range	0 – 70°C
Humidity	5 – 95%
Connectors	Double 2x26 headers

5 Technical assistance

In order to obtain technical assistance please contact support@propox.com . In the request please include the following information:

- number of the module version (e.g. REV 1)
- setting of resistors
- a detailed description of the problem

6 Guarantee

The MMsam7s minimodule is covered by a six-month guarantee. All faults and defects not caused by the user will be removed at the Producer's cost. Transportation costs are borne by the buyer.

The Producer takes no responsibility for any damage and defects caused in the course of using the MMsam7s module.

7 Assembly drawings

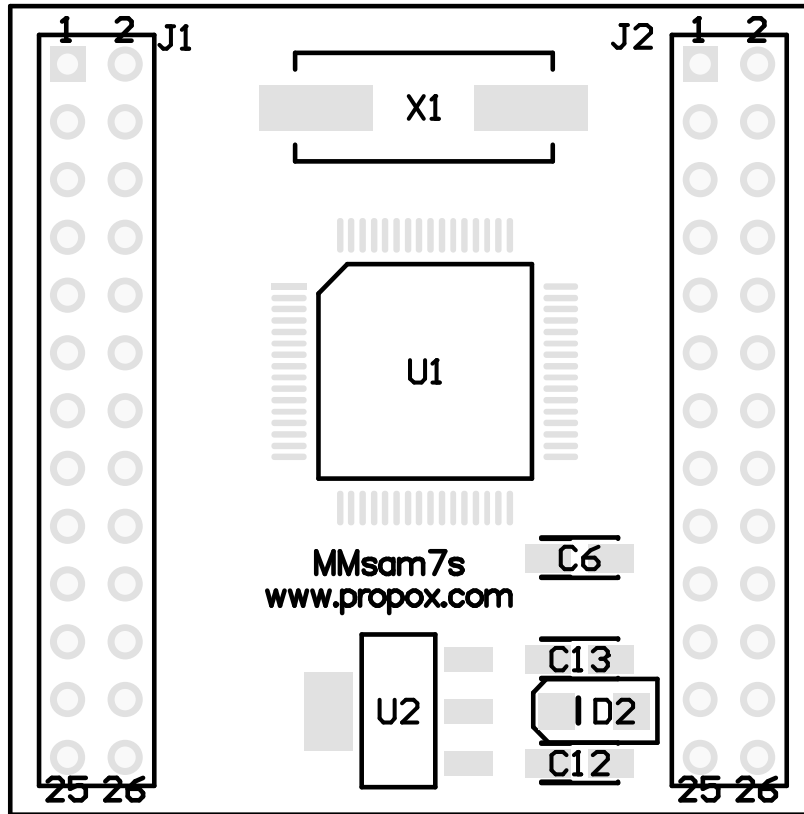

Figure 8 Assembly drawing – top layer.

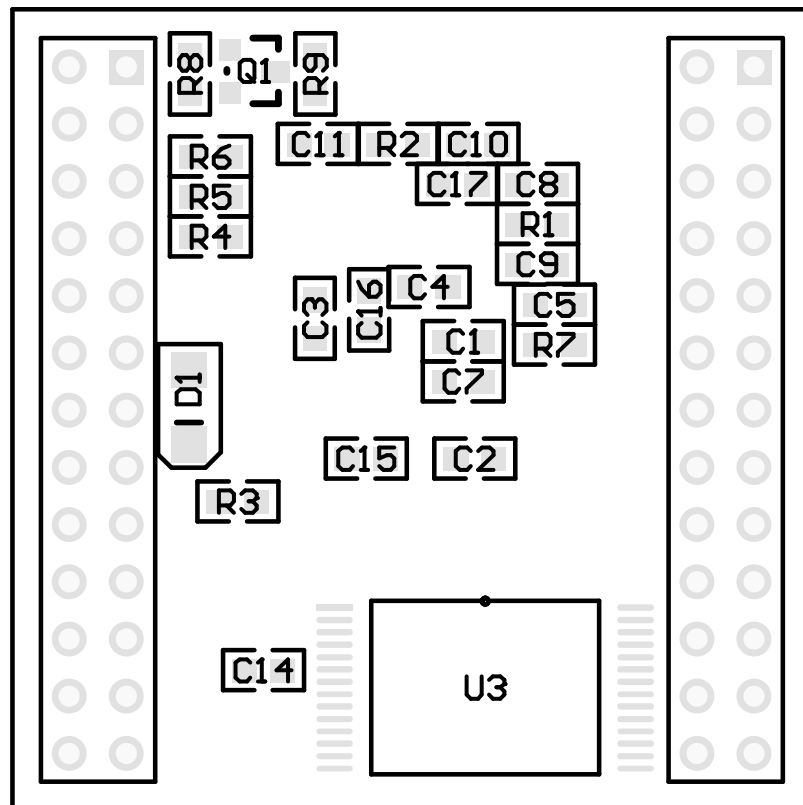

Figure 9 Assembly drawing – bottom layer.

8 Dimensions

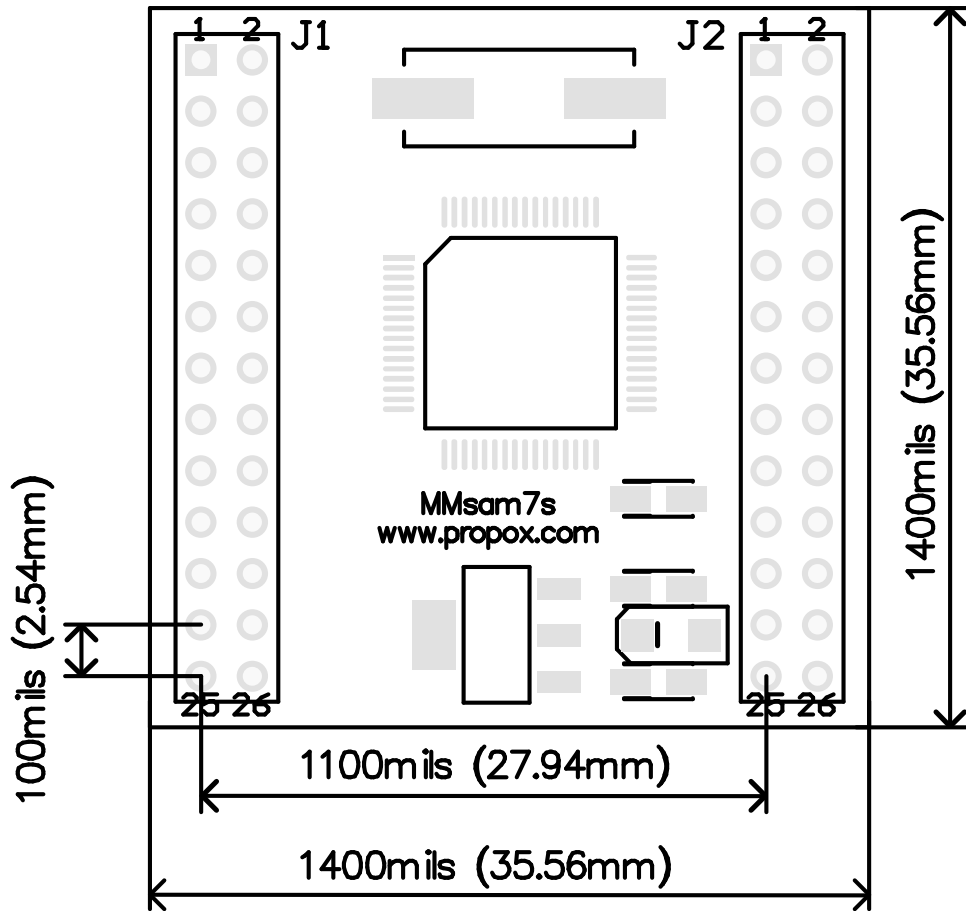
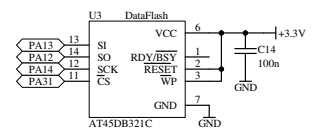
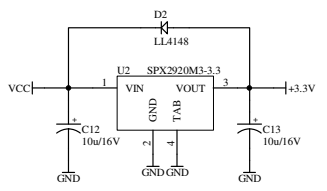
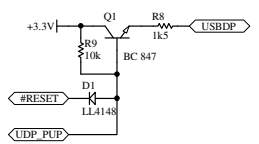
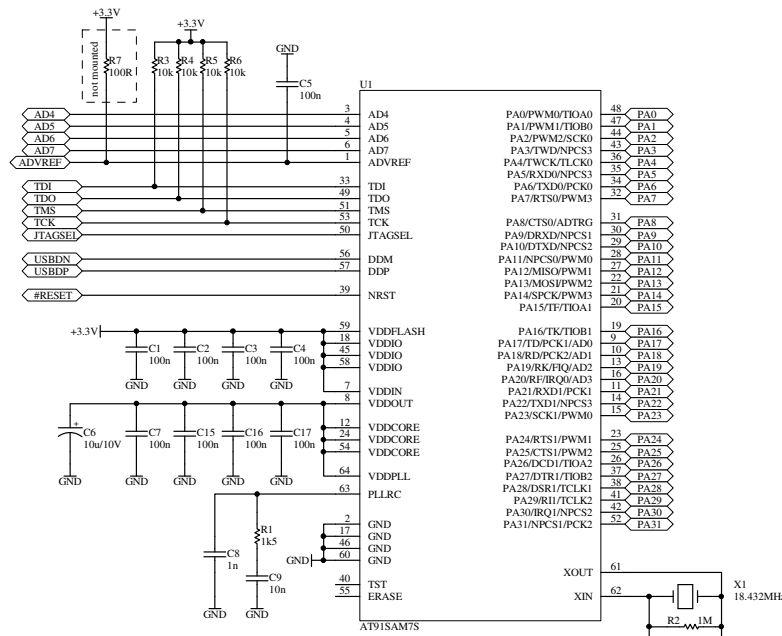

Figure 10 Dimensions - top view.



Figure 11 Dimensions – side view.

9 Schematic



PROPPOX <small>www.propox.com</small>		http://www.propox.com email: support@propox.com	
Title: MMsam7s			
Size:	File:	Rev:	
	Date: 27-04-2005	Sheet 1 of 1	1.00